

Parts List			
TCI Part #	Description	Quantity	Item #
13572	Lug Two 350 kcmil	6	1LK
2401	Hex Hd Bolt 1/2-13 X 1 1/2 In	6	2LK
1610	Nut 1/2-13	6	3LK
1512	Flat Washer 1/2"	12	4LK
1511	Split Lock Washer	6	5LK

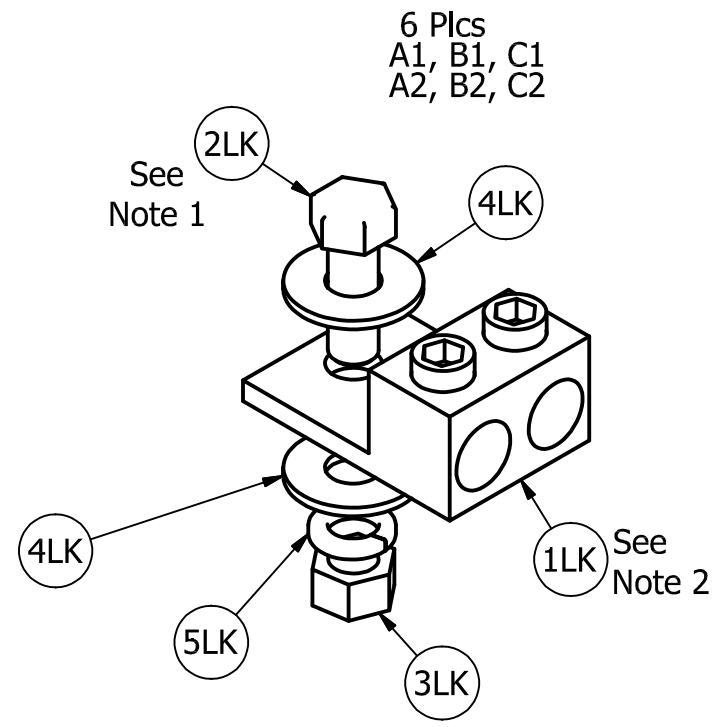
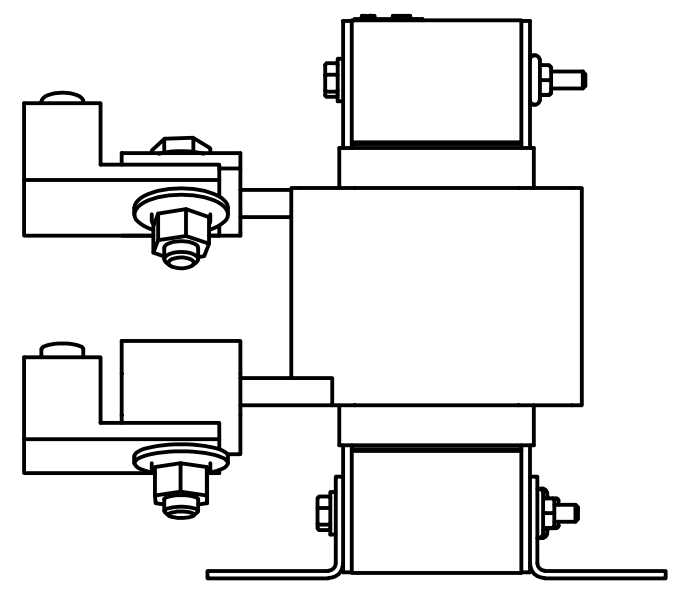
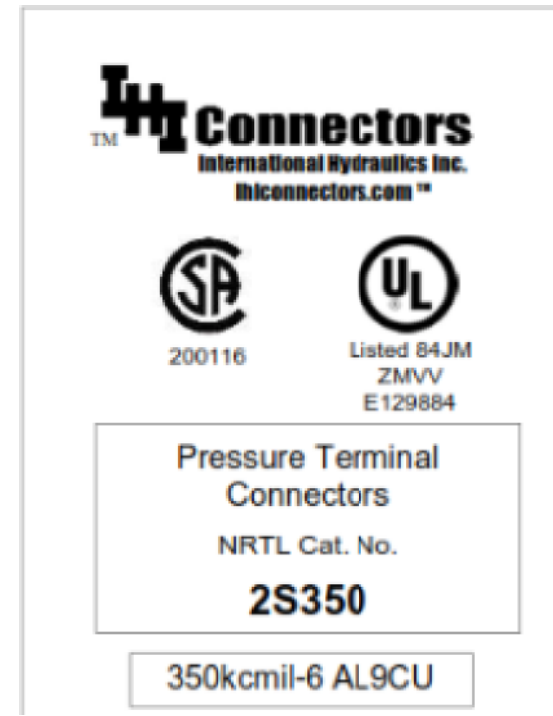

Table 2S350		IHI Connectors		
Wire Size Copper (solid to semi-rigid stranded and metric mm, ##)	Rating C	Wire Size FLEX Copper (#)	Wire Size Aluminum	Torque (all drive means)
350kcmil-2	90	262-2	350-2	375 in-lb (42.4 N-m)
2-6	90	2-4	2-6	275 in-lb (31.1 N-m)



Notes:
 1.) Torque bolt (Item #2LK) to 450 in-lb (50.8 N-m).
 2.) To prevent lug from rotating place lug on underside of tab as shown.

Follow NEC guidelines to determine acceptable wire ampacity requirements.

				TOLERANCES (EXCEPT AS NOTED)		W132 N10611 Grant Drive Germantown, WI 53022	
				DECIMAL			
				.XX ± .25		Lug Kit, 2-350MCM-6	
				.XXX ± .10			
				FRACTIONAL		DRN. BY: JRN	
				± 1/16		DATE: 8/30/17	
				ANGULAR		APRVD:	
				± 1°		LK13-Dwg	
NO	REVISION	DATE	BY			SCALE:	SIZE: B