

Parts List			
TCI Part #	Description	Quantity	Item #
14926	Lug 2/0	6	1LK
1745	Hex Hd Bolt 1/4-20 X 1 In	6	2LK
1505	Nut 1/4-20	6	3LK
1763	Flat Washer 1/4"	12	4LK

Table S2/0					IHI Connectors	
Wire Size Copper (solid to semi-rigid stranded and metric mm ² , ##)	Rating C	Wire Size FLEX Copper (#)	Wire Size Aluminum	Torque (all drive means)		
N/A	90	1/0-1	N/A	75 in-lb (8.5 N-m)		
N/A	90	1-4	N/A	55 in-lb (6.2 N-m)		
2/0-3	90	4-8	2/0-3	50 in-lb (5.6 N-m)		
4-6	90	8-10	4-6	45 in -lb (5.1 N-m)		
8	90	10-14	8	40 in-lb 4.5 N-m)		
10-14	90	N/A	10-12	35 in-lb (4.0 N-m)		

6 Plcs
A1, B1, C1
A2, B2, C2

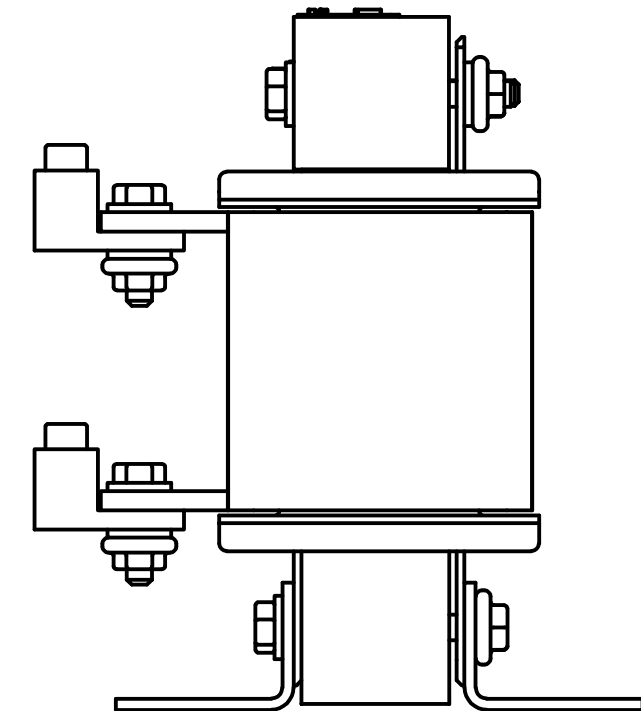
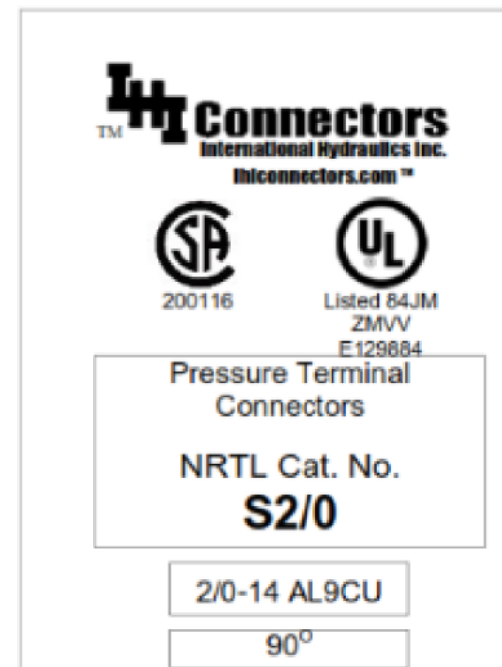
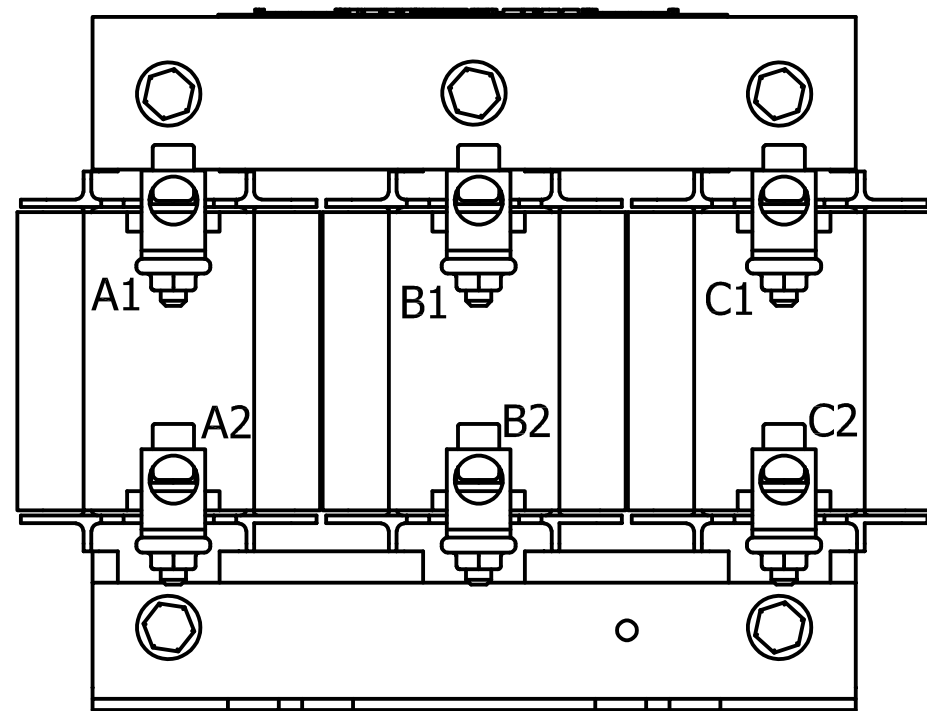
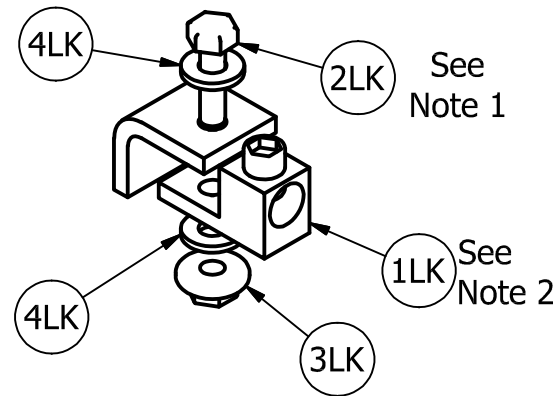

Follow NEC guidelines to determine acceptable wire ampacity requirements.

- Notes:
 1.) Torque bolts (Item #2LK) to 66 in-lb (7.5 N-m).
 2.) To prevent lug from rotating place lug on underside of tab as shown.

				TOLERANCES (EXCEPT AS NOTED)		W132 N10611 Grant Drive Germantown, WI 53022
				DECIMAL		
				.XX ± .25		Lug Kit, 2/0-14
				.XXX ± .10		
				FRACTIONAL		DRN. BY: JRN DATE: 8/30/17 SCALE: APRVD: LK10-Dwg
				± 1/16		
				ANGULAR		SIZE: B SHT.1 OF 1
				± 1°		
NO	REVISION	DATE	BY			