

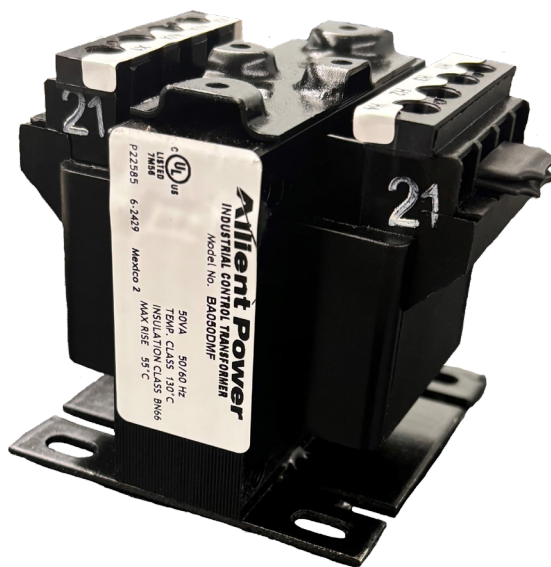

Industrial Control Transformer

CPT

Transforming tomorrow.



Automated manufacturing facilities around the world are using Allient Power's transformers for their reliability to deliver innovation and increase their speed to market.





Table of Contents

CPT Industrial Control Transformers....3
Product Features.....4
Selection Process5
Voltage Groups7
Fusing Accessories.....16
Part Number System18
Connecting Diagrams19

Industrial Control Transformers

Allient Power's Industrial Control Transformers are specially designed to accommodate the momentary current inrush caused when electromagnetic components are energized.

Our CPTs meet or exceed the standards established by UL and cUL over the widest VA range in the industry. The rugged construction and quality electrical characteristics ensure reliable operation of electromagnetic devices and trouble-free performance.

FINGER-SAFE TERMINALS

Terminals are molded into the transformer for extra durability and are finger safe. The deep terminal channels help prevent short circuits from stray wires.

MOUNTING ADAPTOR FOR FUSE BLOCKS

Included on all transformers.

WIRING DIAGRAM

All control power transformers come with wiring diagrams for ease of installation.

QUALITY MATERIALS

High-grade silicon steel laminations and fine quality copper magnet wire reduce core losses and ensure high efficiency.

ENVIRONMENTAL PROTECTION

Rugged construction with fully encapsulated windings protect the transformer from harsh environments for a long life.

PRODUCT LABEL

All control power transformers come labeled with power specifications, agency listings, and manufacturing date codes.

FLEXIBLE MOUNTING

Heavy gauge steel mounting foot ensures a secure installation. Slotted holes allow for flexible mounting locations.

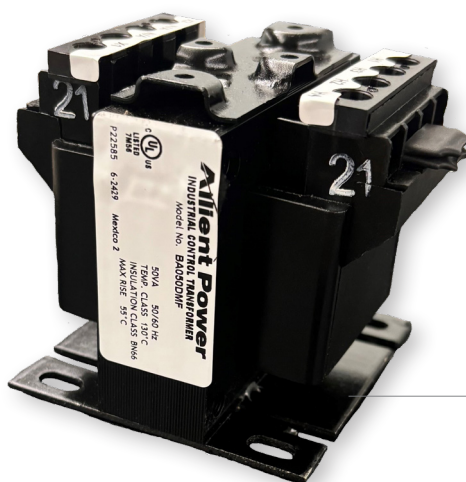

Product Features

- ✓ Enclosed coils (50-5kVA); Completely encloses the transformer coils to protect against moisture, dirt, dust and industrial contaminants for maximum protection in industrial environments.
- ✓ Finger Safe Terminals integrally built in. Up to 30% greater terminal contact area permits low-loss connections. Extra deep barriers reduce the chance of shorts from frayed leads or careless wiring. Pressure plate terminals designed to accept bare wire, ferrules, spade or ring lugs.
- ✓ Attractive black matte finish and easy to read label with complete wiring diagram.
- ✓ Terminals are molded into the transformer for a robust, compact design. A full quarter inch of thread on the terminal screws prevents stripping and pullout.
- ✓ Mounting plate is heavy gauge steel to add strength to core construction and provide stability. Slotted mounting feet permit easy and flexible installation.
- ✓ Two parallel jumper links come standard with transformers when required so they can be wired for dual primary voltages.

Transformer Selection Process

Selecting a transformer for industrial control circuit applications requires knowledge of the following terms:

Inrush VA is the product of load voltage (V) multiplied by the current (A) that is required during circuit start-up. It is calculated by adding the in-rush VA requirements of all devices (contactors, timers, relays, pilot lights, solenoids, etc.), which will be energized together. Inrush VA requirements are best obtained from the component manufacturer.

Sealed VA is the product of load voltage (V) multiplied by the current (A) after initial start-up or under normal operating conditions. It is calculated by adding the sealed VA requirements of all electrical components that will be energized at any given time. Sealed VA requirements are best obtained from the component manufacturer. Sealed VA is also referred to as steady state VA.

Primary Voltage is the voltage available from the electrical distribution system and its operational frequency, which is connected to the transformer supply voltage terminals.

Secondary Voltage is the voltage required for load operation which is connected to the transformer load voltage terminals.

INRUSH REGULATION DATA CHART

INRUSH VA @ 0.4 POWER FACTOR

Continuous VA Transformer Nameplate Rating	85% Secondary Voltage	90% Secondary Voltage	95% Secondary Voltage
25	125	100	75
50	200	167	131
75	311	257	200
100	471	377	276
150	923	716	491
200	1125	883	622
250	1944	1476	970
300	2040	1547	1020
350	3300	2400	1400
500	3191	2500	1745
750	6025	4520	2915
1000	8100	5600	3000
1500	16000	12000	6600
2000	19500	13500	7300
3000	25500	18250	10500
5000	75000	56000	33000



Once the circuit variables have been determined, transformer selection is a simple 5-step process.

1

Determine the application inrush VA by using the following industry accepted formula:

$$\text{Application Inrush VA} = \sqrt{(\text{Inrush VA})^2 + (\text{Sealed VA})^2}$$

2

Refer to the Regulation Data Chart. If the primary voltage is basically stable and does not vary by more than 5% from nominal, the 90% secondary voltage column should be used. If the primary voltage varies between 5% and 10% of nominal, the 95% secondary voltage column should be used.

3

After determining the proper secondary voltage column, read down until a value equal to or greater than the application inrush VA is found. In no case should a figure less than the application inrush VA be used.

4

Read left to the Transformer VA Rating column to determine the proper transformer for this application. As a final check, make sure that the Transformer VA Rating is equal to or greater than the total sealed requirements. If not, select a transformer with a VA rating equal to or greater than the total sealed VA.

5

Refer to the following pages to determine the proper catalog number based on the transformer VA, and primary and secondary voltage requirements.

Voltage Groups

CPT Industrial Control Transformers are available in a wide variety of primary and secondary voltages, many displayed below. If you do not see the voltages required for your application, contact us about a customized option.

VOLTAGE TABLE

Group	Primary	Secondary	VA Sizes
A	220 x 440, 230 x 460, 240 x 480	110, 115, 120	50 - 5000
B	240 x 480	24	50 - 750
C	120 x 240	24	50 - 750
E	550, 575, 600	110, 115, 120	50 - 750
F	208/277	120	50 - 750
G	200/220/440, 208/230/460, 240/480	110, 115, 120	50 - 3000
I	380/400/415	110/220	50 - 5000
J	200/208, 220/230/240, 440/460/480	23 x 110, 24 x 115, 25 x 120	50 - 500
K	240 x 480	120 x 240	50 - 3000

Image is a general representation of a typical Allient Power Control Transformer without fusing accessories or jumper links. Transformers 50VA - 350VA have 4 terminals per side, and units 500VA and higher have 6 terminals per side.

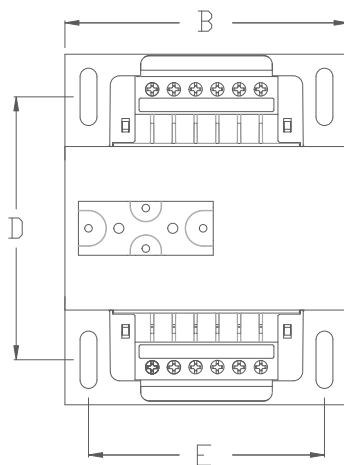

Top view

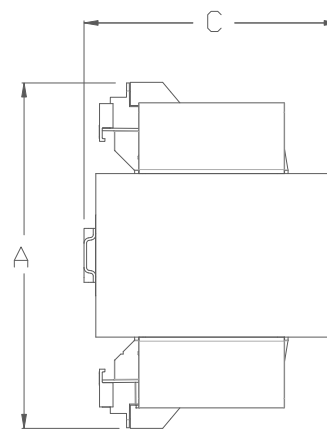

Side view

VOLTAGE GROUP A

240x480, 230x460, 220x440 PRIMARY VOLTS: 110/115/120 SECONDARY VOLTS 50/60 Hz

Approximate Dimensions and Weight

VA Rating	Part #	Max. Depth (A)	Max. Width (in.) (B)	Max. Height (in.) (C)	Mounting Depth (in.) (D)	Mounting Width (in.) (E)	Mounting Hole Depth	Mounting Hole Width	Shipping Weight (lbs.)
50	BA050DMF	3.23	3.00	2.79	2.00	2.50	0.203	0.406	2.6
75	BA075DMF	3.73	3.00	2.79	2.50	2.50	0.203	0.406	3.5
100	BA100DMF	4.23	3.38	3.10	2.38	2.81	0.203	0.406	4.2
150	BB150DMF	4.18	3.75	3.41	2.88	3.13	0.203	0.406	6.7
200	BB200DMF	3.96	4.50	4.04	2.50	3.75	0.203	0.406	8.5
250	BB250DMF	4.46	4.50	4.04	2.88	3.75	0.203	0.406	10.0
300	BB300DMF	4.46	4.50	4.04	3.25	3.75	0.203	0.406	11.3
350	BB350DMF	5.19	4.50	4.04	3.75	3.75	0.203	0.406	13.6
500	BB500DMF	5.17	5.25	4.66	4.25	4.38	0.313	1.063	19.2
750	BB750DMF	6.42	5.25	4.66	5.38	4.38	0.313	1.063	28.1
1000	BH1K0DMF	6.23	7.00	5.65	4.00	6.13	0.313	1.063	29.8
1500	BH1K5DMF	7.23	7.00	5.65	4.50	6.13	0.313	1.063	30.0
2000	BH2K0DMF	7.98	7.00	5.65	5.13	6.13	0.313	1.063	38.0
3000	BH3K0DMF	7.82	9.00	7.62	4.25	6.50	0.438	1.000	53.0
5000	BH5K0DMF	8.81	9.00	7.62	7.25	7.50	0.438	1.000	89.0

VOLTAGE GROUP B

240 x 480 PRIMARY VOLTS 24 SECONDARY VOLTS 50/60 Hz

Approximate Dimensions and Weight

VA Rating	Part #	Max. Depth (A)	Max. Width (B)	Max. Height (C)	Mounting Depth (D)	Mounting Width (E)	Mounting Hole Depth	Mounting Hole Width	Shipping Weight (lbs.)
50	BA050BSF	3.32	3.00	2.79	2.00	2.50	0.20	0.41	2.6
75	BA075BSF	3.82	3.00	2.79	2.50	2.50	0.20	0.41	3.5
100	BA100BSF	3.78	3.38	3.11	2.38	2.81	0.20	0.41	4.2
150	BB150BSF	4.27	3.75	3.42	2.88	3.13	0.20	0.41	6.7
200	BB200BSF	4.05	4.50	4.04	2.50	3.75	0.20	0.41	8.5
250	BB250BSF	4.55	4.50	4.04	2.88	3.75	0.20	0.41	10.0
300	BB300BSF	4.55	4.50	4.04	3.25	3.75	0.20	0.41	11.3
350	BB350BSF	5.28	4.50	4.04	3.75	3.75	0.20	0.41	13.6
500	BB500BSF	5.75	5.25	4.66	4.25	4.38	0.31	1.06	15.8
750	BB750BSF	7.00	5.25	4.66	5.38	4.38	0.31	1.06	28.1

VOLTAGE GROUP C

120 x 240 PRIMARY VOLTS 24 SECONDARY VOLTS 50/60 Hz

Approximate Dimensions and Weight

VA Rating	Part #	Max. Depth (A)	Max. Width (B)	Max. Height (C)	Mounting Depth (D)	Mounting Width (E)	Mounting Hole Depth	Mounting Hole Width	Shipping Weight (lbs.)
50	BA050ASF	3.32	3.00	2.79	2.00	2.50	0.20	0.41	2.6
75	BA075ASF	3.82	3.00	2.79	2.50	2.50	0.20	0.41	3.5
100	BA100ASF	3.78	3.38	3.11	2.38	2.81	0.20	0.41	4.2
150	BB150ASF	4.27	3.75	3.42	2.88	3.13	0.20	0.41	6.7
200	BB200ASF	4.05	4.50	4.04	2.50	3.75	0.20	0.41	8.5
250	BB250ASF	4.55	4.50	4.04	2.88	3.75	0.20	0.41	10.0
300	BB300ASF	4.55	4.50	4.04	3.25	3.75	0.20	0.41	11.3
350	BB350ASF	5.28	4.50	4.04	3.75	3.75	0.20	0.41	13.6
500	BB500ASF	5.75	5.25	4.66	4.25	4.38	0.31	1.06	15.8
750	BB750ASF	7.00	5.25	4.66	5.38	4.38	0.31	1.06	28.1

VOLTAGE GROUP E

550, 575, 600 PRIMARY VOLTS 110, 115, 120 SECONDARY VOLTS 50/60 Hz

Approximate Dimensions and Weight

VA Rating	Part #	Max. Depth (A)	Max. Width (B)	Max. Height (C)	Mounting Depth (D)	Mounting Width (E)	Mounting Hole Depth	Mounting Hole Width	Shipping Weight (lbs.)
50	BA050EMF	3.32	3.00	2.79	2.00	2.50	0.20	0.41	2.6
75	BA075EMF	3.82	3.00	2.79	2.50	2.50	0.20	0.41	3.5
100	BA100EMF	3.78	3.38	3.10	2.38	2.81	0.20	0.41	4.2
150	BB150EMF	4.27	3.75	3.41	2.88	3.13	0.20	0.41	6.7
200	BB200EMF	4.05	4.50	4.04	2.50	3.75	0.20	0.41	10.0
250	BB250EMF	4.55	4.50	4.04	2.88	3.75	0.20	0.41	10.0
300	BB300EMF	4.55	4.50	4.04	3.25	3.75	0.20	0.41	10.0
350	BB350EMF	5.28	4.50	4.04	3.75	3.75	0.20	0.41	13.6
500	BB500EMF	5.75	5.25	4.66	4.25	4.38	0.31	1.06	15.9
750	BB750EMF	7.00	5.25	4.66	5.38	4.38	0.31	1.06	28.1
1000	BH1K0EMF	6.61	7.00	5.65	4.00	6.13	0.31	1.06	29.8
1500	BH1K5EMF	7.62	7.00	5.65	4.50	6.13	0.31	1.06	29.8
2000	BH2K0EMF	8.37	7.00	5.65	5.13	6.13	0.31	1.06	29.8
3000	BH3K0EMF	7.82	9.00	7.62	4.25	6.50	0.44	1.00	29.8
5000	BH5K0EMF	9.06	9.00	7.62	7.25	7.50	0.44	1.00	10.0

VOLTAGE GROUP F

208/277 PRIMARY VOLTS 120 SECONDARY VOLTS 50/60 Hz

Approximate Dimensions and Weight

VA Rating	Part #	Max. Depth (A)	Max. Width (B)	Max. Height (C)	Mounting Depth (D)	Mounting Width (E)	Mounting Hole Depth	Mounting Hole Width	Shipping Weight (lbs.)
50	BA050WQF	3.23	3.00	2.79	2.00	2.50	0.20	0.41	2.6
75	BA075WQF	3.73	3.00	2.79	2.50	2.50	0.20	0.41	3.5
100	BA100WQF	3.69	3.38	3.11	2.38	2.81	0.20	0.41	4.2
150	BB150WQF	4.17	3.75	3.42	2.88	3.13	0.20	0.41	6.7
200	BB200WQF	3.96	4.50	4.04	2.88	3.75	0.20	0.41	8.5
250	BB250WQF	4.47	4.50	4.04	3.25	3.75	0.20	0.41	10.0
300	BB300WQF	4.47	4.50	4.04	3.25	3.75	0.20	0.41	11.3
350	BB350WQF	5.19	4.50	4.04	3.75	3.75	0.20	0.41	13.6
500	BB500WQF	5.17	5.25	4.66	4.25	4.38	0.31	1.06	15.8
750	BB750WQF	6.42	5.25	4.66	5.38	4.38	0.31	1.06	28.1
1000	BH1000WQF	6.61	7.00	5.65	4.00	6.13	0.31	1.06	29.8

VOLTAGE GROUP G

460/230/208,480/240,440/220/200 PRIMARY VOLTS: 110/115/120 SECONDARY VOLTS 50/60Hz

Approximate Dimensions and Weight

VA Rating	Part #	Max. Depth (A)	Max. Width (B)	Max. Height (C)	Mounting Depth (D)	Mounting Width (E)	Mounting Hole Depth	Mounting Hole Width	Shipping Weight (lbs.)
50	BA050CMF	3.23	3.00	2.79	2.00	2.50	0.203	0.406	2.6
75	BA075CMF	3.73	3.00	2.79	2.50	2.50	0.203	0.406	3.5
100	BA100CMF	4.23	3.38	3.10	2.38	2.81	0.203	0.406	4.2
150	BB150CMF	4.18	3.75	3.41	2.88	3.13	0.203	0.406	6.7
200	BB200CMF	3.96	4.50	4.04	2.50	3.75	0.203	0.406	8.5
250	BB250CMF	4.46	4.50	4.04	2.88	3.75	0.203	0.406	10.0
300	BB300CMF	4.46	4.50	4.04	3.25	3.75	0.203	0.406	11.3
350	BB350CMF	5.19	4.50	4.04	3.75	3.75	0.203	0.406	13.6
500	BB500CMF	5.17	5.25	4.66	4.25	4.38	0.313	1.063	19.2
750	BB750CMF	6.42	5.25	4.66	5.38	4.38	0.313	1.063	28.1
1000	BH1K0CMF	6.23	7.00	5.65	4.00	6.13	0.313	1.063	29.8
1500	BH1K5CMF	7.23	7.00	5.65	4.50	6.13	0.313	1.063	30.0
2000	BH2K0CMF	7.98	7.00	5.65	5.13	6.13	0.313	1.063	38.0
3000	BH3K0CMF	7.82	9.00	7.62	4.25	6.50	0.438	1.000	53.0
5000	BH5K0CMF	8.81	9.00	7.62	7.25	7.50	0.438	1.000	89.0

VOLTAGE GROUP I

380/400/415 PRIMARY VOLTS: 110/220 SECONDARY VOLTS 50/60Hz

Approximate Dimensions and Weight

VA Rating	Part #	Max. Depth (A)	Max. Width (B)	Max. Height (C)	Mounting Depth (D)	Mounting Width (E)	Mounting Hole Depth	Mounting Hole Width	Shipping Weight (lbs.)
50	BA050ZPF	3.32	3.00	2.79	2.00	2.50	0.20	0.41	2.6
75	BA075ZPF	3.82	3.00	2.79	2.50	2.50	0.20	0.41	3.5
100	BA100ZPF	3.78	3.38	3.11	2.38	2.81	0.20	0.41	4.2
150	BB150ZPF	4.27	3.75	3.42	2.88	3.13	0.20	0.41	6.7
200	BB200ZPF	4.05	4.50	4.04	2.50	3.75	0.20	0.41	8.5
250	BB250ZPF	4.55	4.50	4.04	2.88	3.75	0.20	0.41	10.0
300	BB300ZPF	4.55	4.50	4.04	3.25	3.75	0.20	0.41	11.3
350	BB350ZPF	5.28	4.50	4.04	3.75	3.75	0.20	0.41	13.6
500	BB500ZPF	5.75	5.25	4.66	4.25	4.38	0.31	1.06	16.1
750	BB750ZPF	7.00	5.25	4.66	5.38	4.38	0.31	1.06	28.1
1000	BH1K0ZPF	6.21	7.00	5.65	6.21	7.00	0.31	1.06	29.8
1500	BH1K5ZPF	7.23	7.00	5.65	7.23	7.00	0.31	1.06	30.0
2000	BH2K0ZPF	7.98	7.00	5.43	7.98	7.00	0.31	1.06	38.0
3000	BH3K0ZPF	7.50	9.00	7.62	7.50	9.00	0.44	1.00	53.0
5000	BH5K0ZPF	9.00	9.00	7.62	9.00	9.00	0.44	1.00	89.0

VOLTAGE GROUP J

200/208, 220/230/240, 440/460/480 PRIMARY VOLTS 23 x 110, 24 x 115, 25 x 120 SECONDARY VOLTS 50/60 Hz

Approximate Dimensions and Weight

VA Rating	Part #	Max. Depth (A)	Max. Width (B)	Max. Height (C)	Mounting Depth (D)	Mounting Width (E)	Mounting Hole Depth	Mounting Hole Width	Shipping Weight (lbs.)
45	TBA	3.73	3.00	2.79	2.50	2.50	0.20	0.41	3.5
50	BA050CLF	3.73	3.00	2.79	2.50	2.50	0.20	0.41	3.5
75	BA075CLF	3.69	3.38	3.11	2.38	2.81	0.20	0.41	4.2
100	BA100CLF	4.17	3.75	3.42	2.88	3.13	0.20	0.41	6.7
150	BB150CLF	4.17	3.75	3.42	2.88	3.13	0.20	0.41	6.7
200	BB200CLF	4.47	4.50	4.04	2.88	3.75	0.20	0.41	10.0
250	BB250CLF	5.19	4.50	4.04	3.75	3.75	0.20	0.41	13.6
300	BB300CLF	5.19	4.50	4.04	3.75	3.75	0.20	0.41	13.6
350	BB350CLF	5.17	5.25	4.66	4.25	4.38	0.31	1.06	16.2
500	BB500CLF	6.42	5.25	4.66	5.38	4.38	0.31	1.06	28.1
750	BB750CLF	7.23	7.00	5.65	4.00	6.13	0.31	1.06	30.0
1000	BH1K0CLF	7.98	7.00	5.43	5.13	6.13	0.31	1.06	38.0
1500	BH1K5CLF	7.98	7.00	5.43	5.13	6.13	0.31	1.06	38.0
2000	BH2K0CLF	7.98	7.00	5.43	5.13	6.13	0.31	1.06	38.0

VOLTAGE GROUP K

240 x 480 PRIMARY VOLTS 120 x 240 SECONDARY VOLTS 50/60Hz

Approximate Dimensions and Weight

VA Rating	Part #	Max. Depth (A)	Max. Width (B)	Max. Height (C)	Mounting Depth (D)	Mounting Width (E)	Mounting Hole Depth	Mounting Hole Width	Shipping Weight (lbs.)
50	BA050BAF	3.41	3.00	2.79	2.00	2.50	0.20	0.41	2.6
75	BA075BAF	3.91	3.00	2.79	2.50	2.50	0.20	0.41	3.5
100	BA100BAF	3.86	3.38	3.10	2.38	2.81	0.20	0.41	4.2
150	BB150BAF	4.36	3.75	3.41	2.88	3.13	0.20	0.41	6.7
200	BB200BAF	4.14	4.50	4.04	2.50	3.75	0.20	0.41	8.5
250	BB250BAF	4.64	4.50	4.04	2.88	3.75	0.20	0.41	10.0
300	BB300BAF	4.64	4.50	4.04	3.25	3.75	0.20	0.41	11.3
350	BB350BAF	5.37	4.50	4.04	3.75	3.75	0.20	0.41	13.6
500	BB500BAF	5.75	5.25	4.66	4.25	4.38	0.31	1.06	17.3
750	BB750BAF	6.74	5.25	4.66	5.38	4.38	0.31	1.06	28.1
1000	BH1K0BAF	7.01	7.00	5.65	5.38	4.38	0.31	1.06	29.8
1500	BH1K5BAF	8.00	7.00	5.65	4.50	6.13	0.31	1.06	30.0
2000	BH2K0BAF	8.76	7.00	5.65	5.13	6.13	0.31	1.06	38.0
3000	BH3K0BAF	8.14	9.00	7.62	4.25	6.50	0.44	1.00	53.0
5000	BH5K0BAF	9.14	9.00	7.62	7.25	7.50	0.44	1.00	89.0

Fusing Accessories

FACTORY INSTALLED OPTION: 0

(FA-06 or FA-07 Kit)
Secondary Fuse Clip
(13/32" x 1 1/2" Midget Fuse)

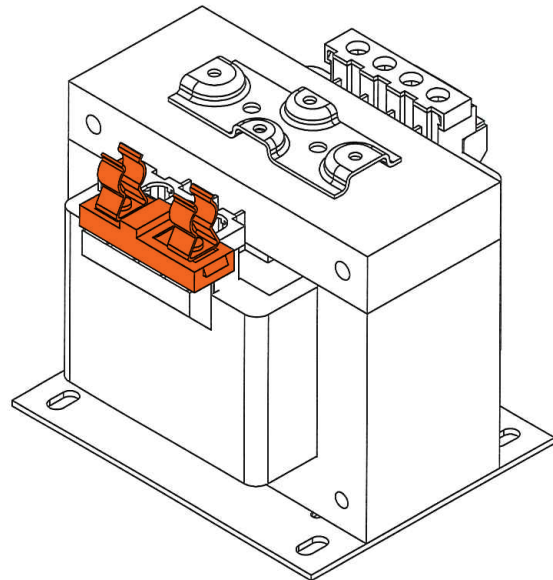

FACTORY INSTALLED OPTION: 4

(FA-11 Kit)
Primary Fuse Block & Secondary
Fuse Clips (Class CC Fuses (PRI))
& 13/32" x 1 1/2" Midget Fuse (SEC))

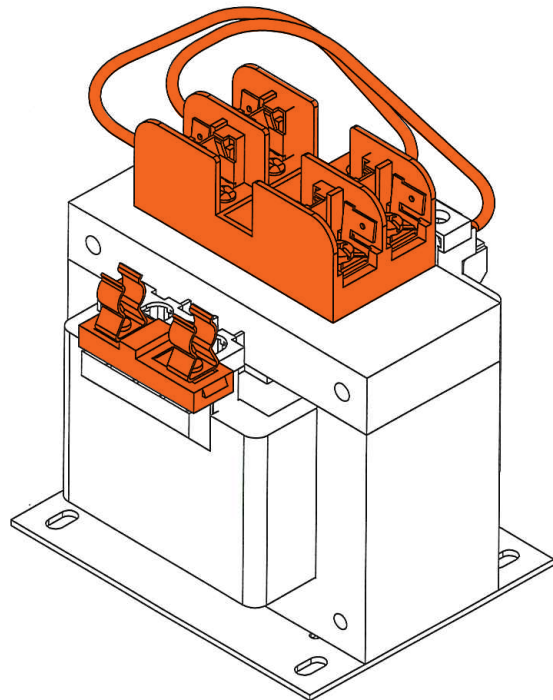

ACCESSORIES

Part #	SKU #	Fusing Options
FA-00	P23722	Primary Fuse Cover with Puller - fits any fuse block
FA-01	P24286	Primary Fuse Cover with Puller - fits any fuse block (25 pack)
FA-02	P23724	Primary Fuse Cover with Puller - fits any fuse block (50 pack)
FA-03	P24290	Secondary Fuse Cover - fits any secondary fuse clup
FA-04	P24291	Secondary Fuse Cover - fits any secondary fuse clip (25 pack)
FA-05	P24292	Secondary Fuse Cover - fits any secondary fuse clip (50 pack)
FA-06	P23725	Secondary Fuse Clip fits 50-750VA
FA-07	P24665	Secondary Fuse Clip fits 1-5VA
FA-08	P24084	Single Pole Secondary Fuse Block - fits all models
FA-09	P23721	Dual Pole Primary Fuse Block - fits all models
FA-10	P24085	Dual Pole Primary Fuse Block and Secondary Fuse Block - fits 150V A+
FA-11	P24086	Dual Pole Primary Fuse Block and Secondary Fuse Clip
FA-12	P25073	Terminal Covers 4 Position W/O Fuse, 50-350V A Frame (25 pack)
FA-13	P25074	Terminal Covers 4 Position W/Fuse, 50-350V A Frame (25 pack)
FA-14	P25075	Terminal Covers 6 Position W/O Fuse, 500-750V A Frame (25 pack)
FA-15	P25076	Terminal Covers 6 Position W.Fuse, 500-750V A Frame (25 pack)
FA-16	P25077	Terminal Covers 6 Position, 1000-5000V A Frame (25 pack)

Part Numbering System

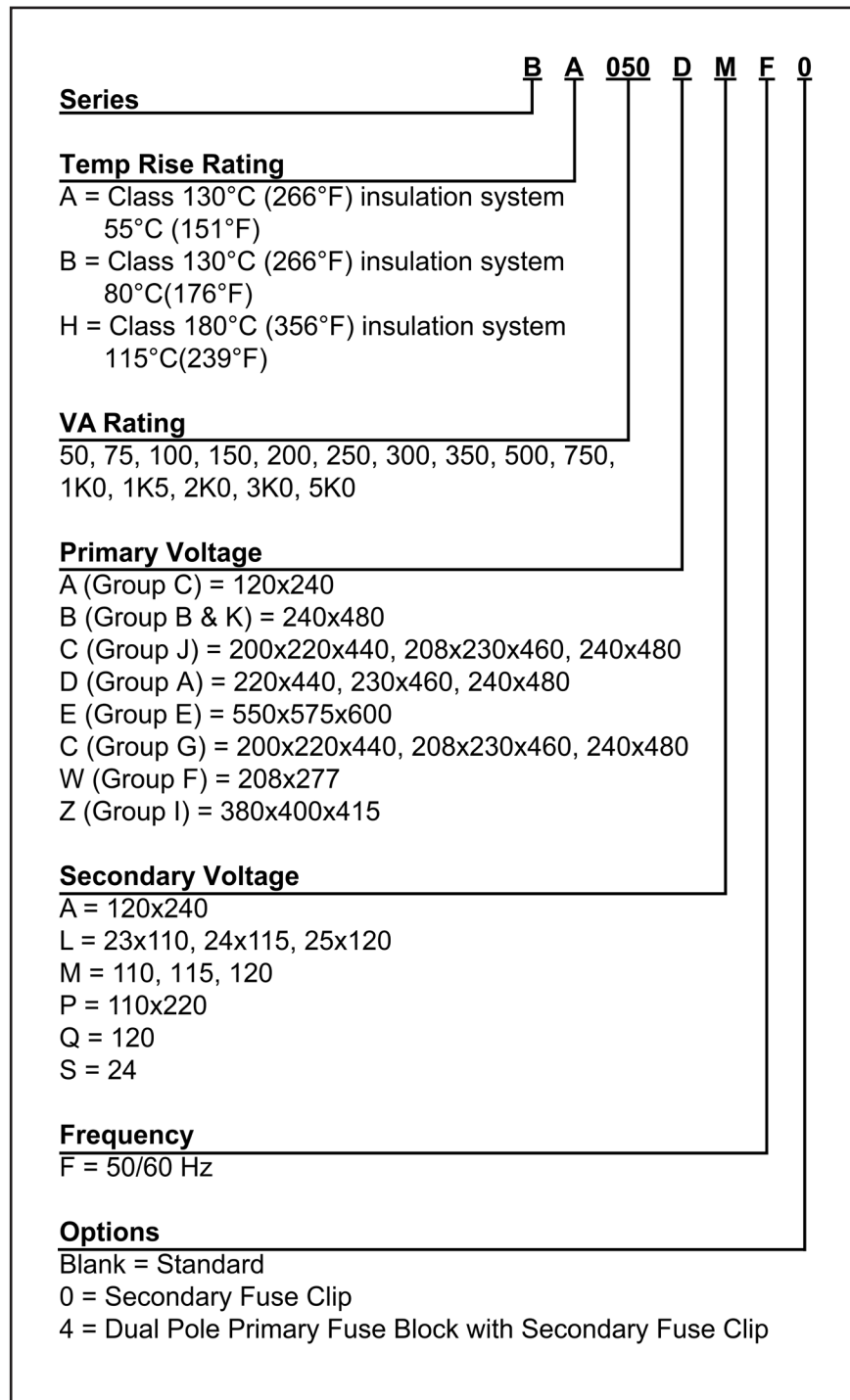

Connection Diagrams

GROUP A

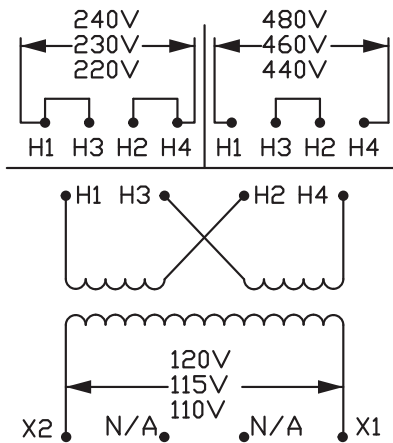

GROUP B

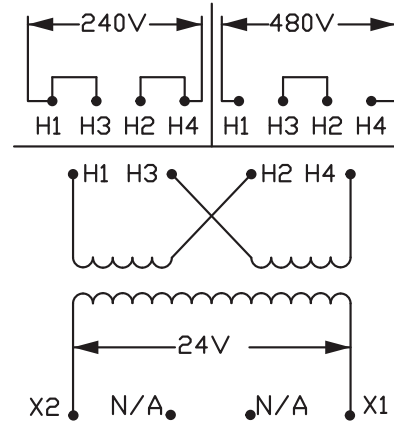

GROUP C

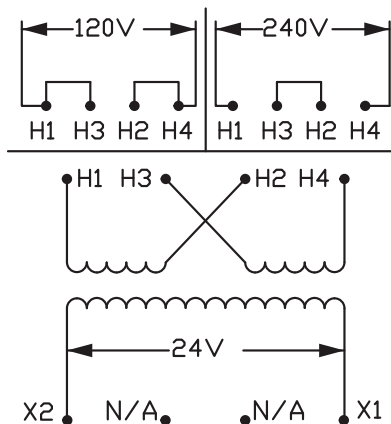

GROUP E

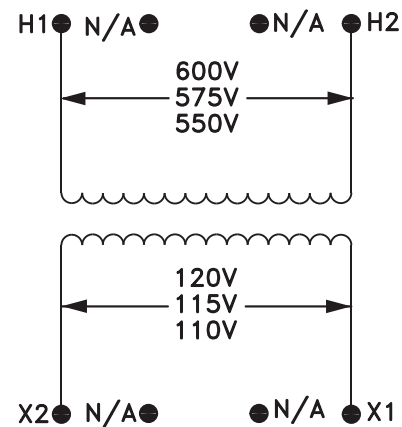

Connection Diagrams

GROUP F

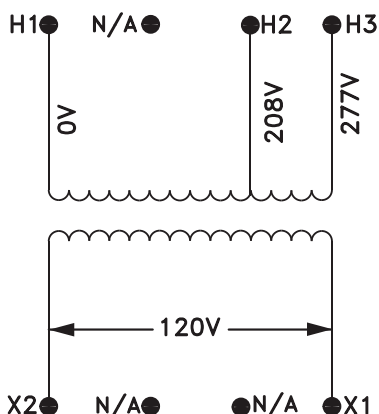

GROUP G

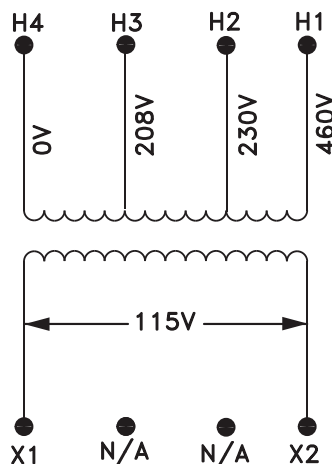

GROUP I

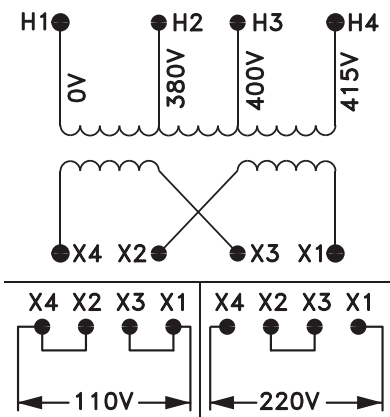

GROUP J

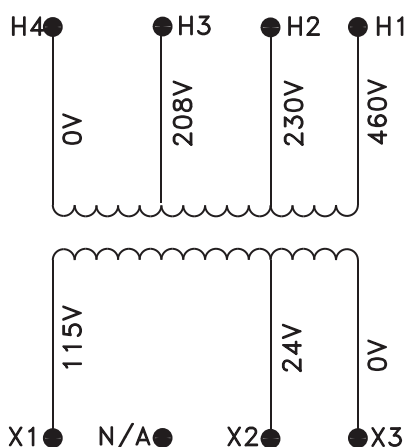

GROUP K

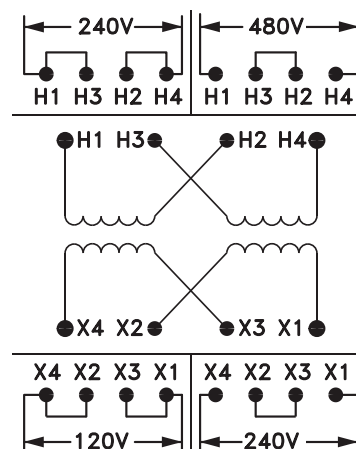

Learn more about how our products can positively impact your operation.

www.transcoil.com | marketing@transcoil.com | 800-824-8282