

TCI Part Number	Horsepower (HP)	Rated Amps (A)	Rated Voltage (V)	--uH +8%/-2%	Approx Weight (LBS)
KTR3A65HL	20	7.6	480	8730	16

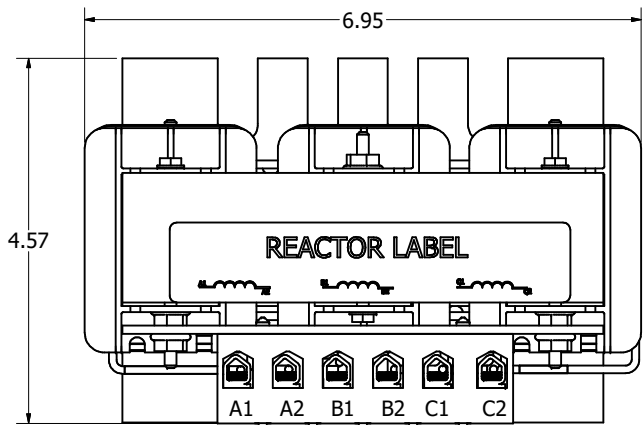

TERMINAL BLOCK TORQUE (LB-IN)
WIRE RANGE #4 AWG. TO #18 AWG. = (20 LB-IN)

NOTE: MARKINGS A1,A2,B1,B2,C1,C2 ON Terminal Block And Coils , FOR REFERENCE ONLY.

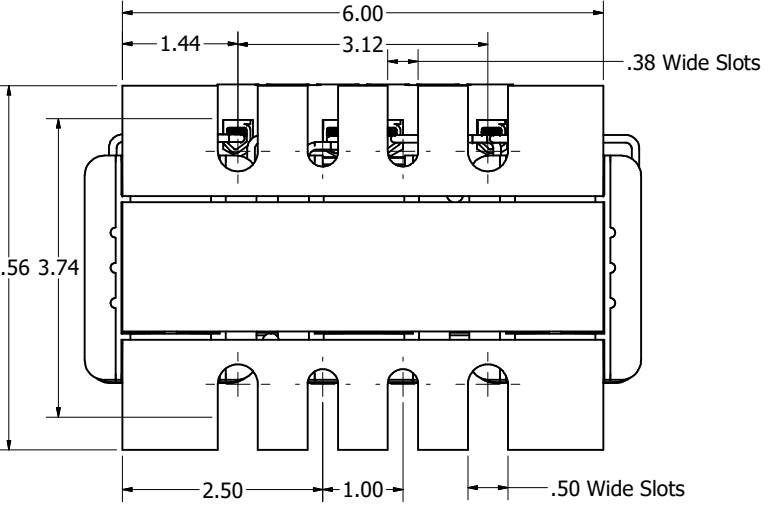
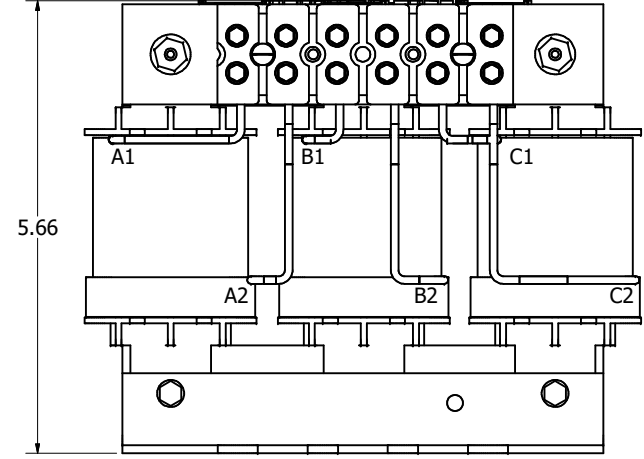
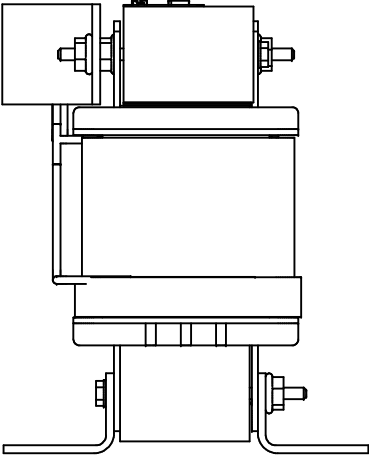
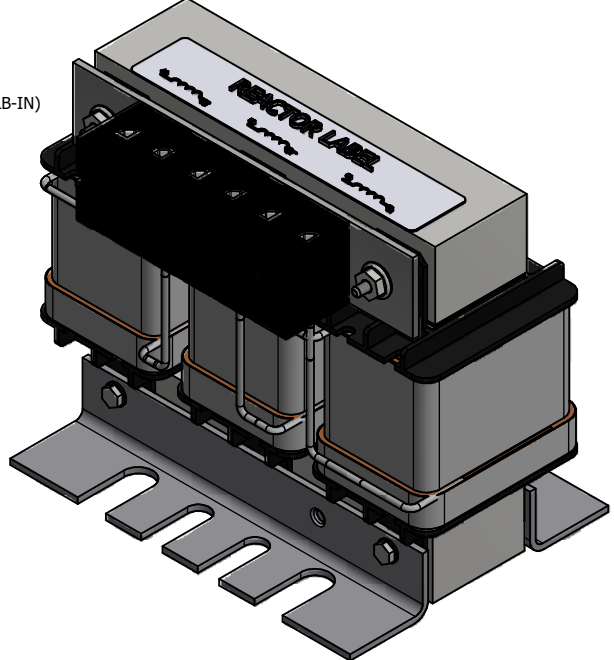

Material(s) Shall be RoHS Compliant

				TOLERANCES (EXCEPT AS NOTED)		 W132 N10611 Grant Drive Germantown, WI 53022
				DECIMAL		
				.XX +/- .25		
				.XXX +/- .12		
				FRACTIONAL		
				+/- 1/16		
C5378, Design updated				9/1/202	DSW	DRN. BY DSW
NO REVISION				DATE	BY	DATE 11/21/2014
				+/- 1		APPRVD. SCALE 1/1 2
						DWG. No. 107171DG
						SHEET 1 OF 1