

Wire Range: 1- 4 AWG. Torque : 35 IN-LBS (3.95 Nm)
 6- 14 AWG. Torque : 30 IN-LBS (3.39 Nm)
 16- 20 AWG. Torque : 25 IN-LBS (2.28 Nm)
 22 AWG. Torque : 20 IN-LBS (2.26 Nm)

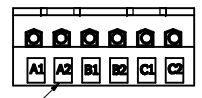

(Customer Connections)
 Markings On Terminal Block
 For Reference Only.

| TCI Part Number | Horsepower (HP) | Amps | ---uH +8%/-2% | Approx Weight (LBS) |
|-----------------|-----------------|------|------------------|---------------------|
| KTR32L55HGX1 | 100.5 | 74.3 | 702 | 68 |

System Voltage 400V 50Hz.

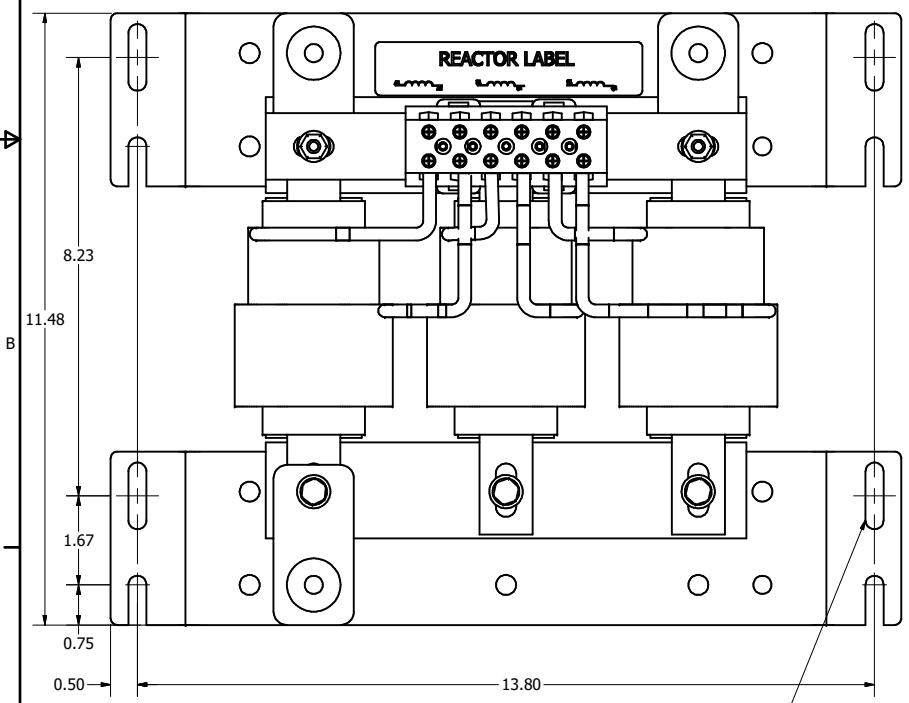
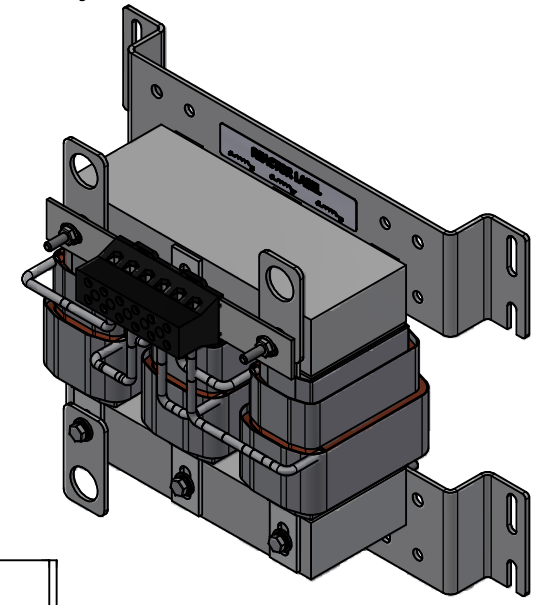

0.34" Wide x 1.25" Long Slots, 4 Places.

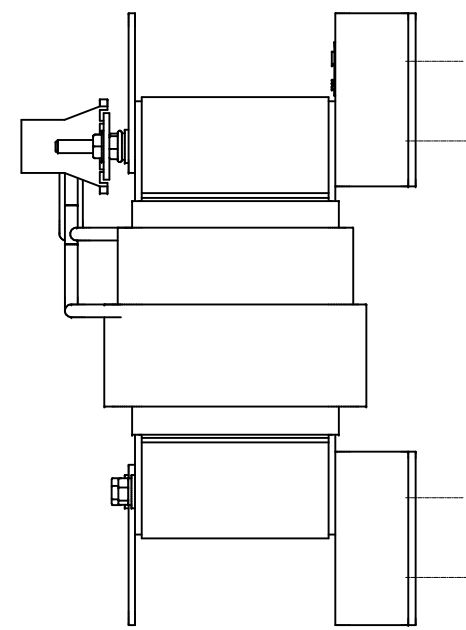

Strip 1.80, 3.50 Stack

Customer Is Responsible For Installation to Meet All National And Local Electrical Codes.

Material(s) Shall be RoHS Compliant

| | | | | | | |
|--|----|-------------------------|----------|------------------------------|--|--|
| THE INFORMATION AND DESIGNS CONTAINED IN THIS DRAWING ARE CONFIDENTIAL AND THE PROPRIETARY PROPERTY OF ALLIED MOTION TECHNOLOGIES INC. AND ITS SUBSIDIARIES. NEITHER THIS DESIGN NOR ANY INFORMATION CONTAINED IN THIS DRAWING MAY BE REPRODUCED OR DISCLOSED TO OTHERS WITHOUT THE EXPRESS WRITTEN CONSENT OF ALLIED MOTION TECHNOLOGIES INC. AND ITS SUBSIDIARIES. | | | | TOLERANCES (EXCEPT AS NOTED) |  W132N10611 (Rev 1) 11/16/20 Germantown, WI 53022 © 2024 TCI, LLC An Allied Motion Company KTR32L55HGX1 Wall Mounted, 13.8" CC Spacing | |
| | | | | DECIMAL | | |
| | | | | .XX ± .25 .XXX ± .10 | | |
| | | | | FRACTIONAL | | |
| | | | ANGULAR | ± 1/16 | | |
| | A | 6793, Was KTR32L55HGXP1 | 9/9/2024 | DSW | DRN BY: DSW DATE: 9/9/2024 | |
| | NO | REVISION | DATE | BY | SCALE: 1/2 DRAWN: TCI | |

109646DG

SHT 1 OF 1