

TCI Part Number	Horsepower (HP)	Amps	---uH +8%/-2%	Weight (LBS)
KTR15A65HG4	50	28.70	1844	50

Wire Range: 1- 4 AWG. Torque : 35 IN-LBS (3.95 Nm)
 6- 14 AWG. Torque : 30 IN-LBS (3.39 Nm)
 16- 20 AWG. Torque : 25 IN-LBS (2.28 Nm)
 22 AWG. Torque : 20 IN-LBS (2.26 Nm)

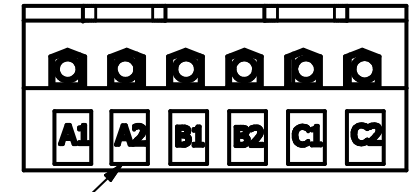

(Customer Connections)
 Markings On Terminal Block
 For Reference Only.

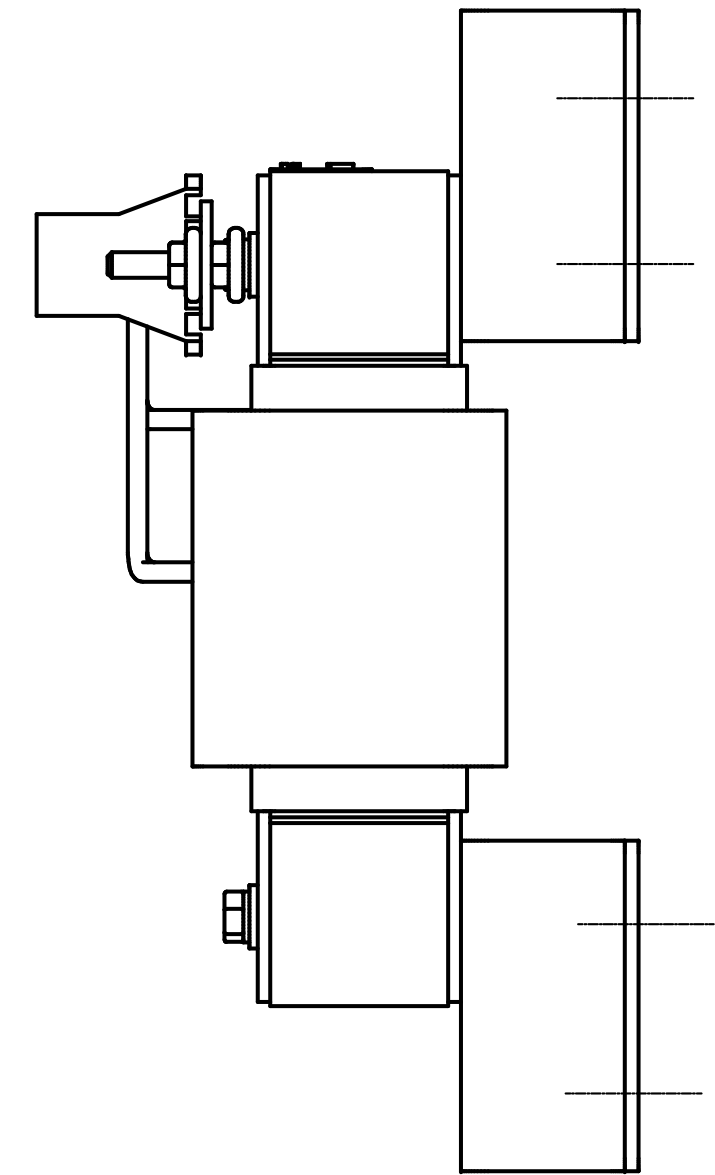
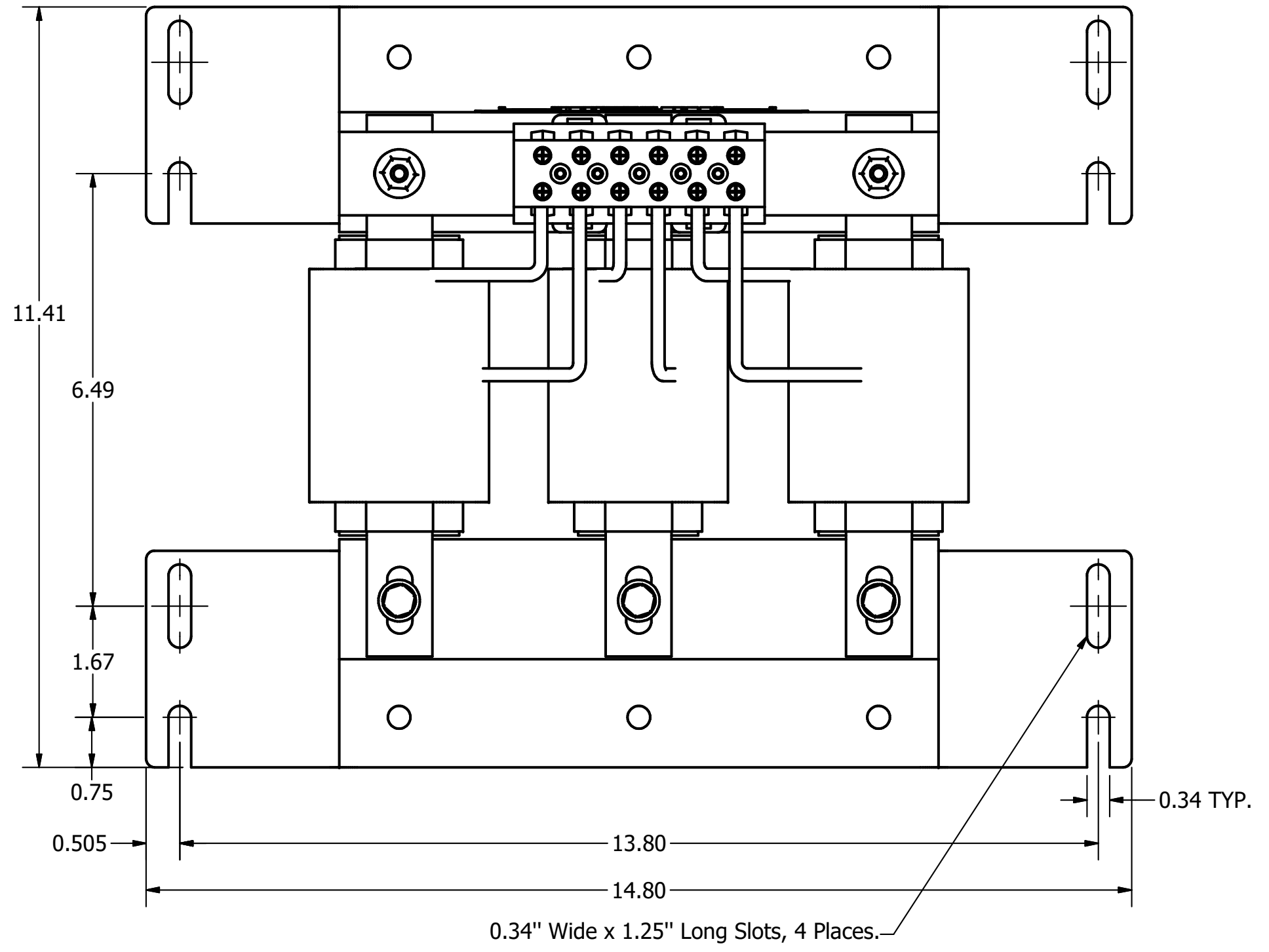
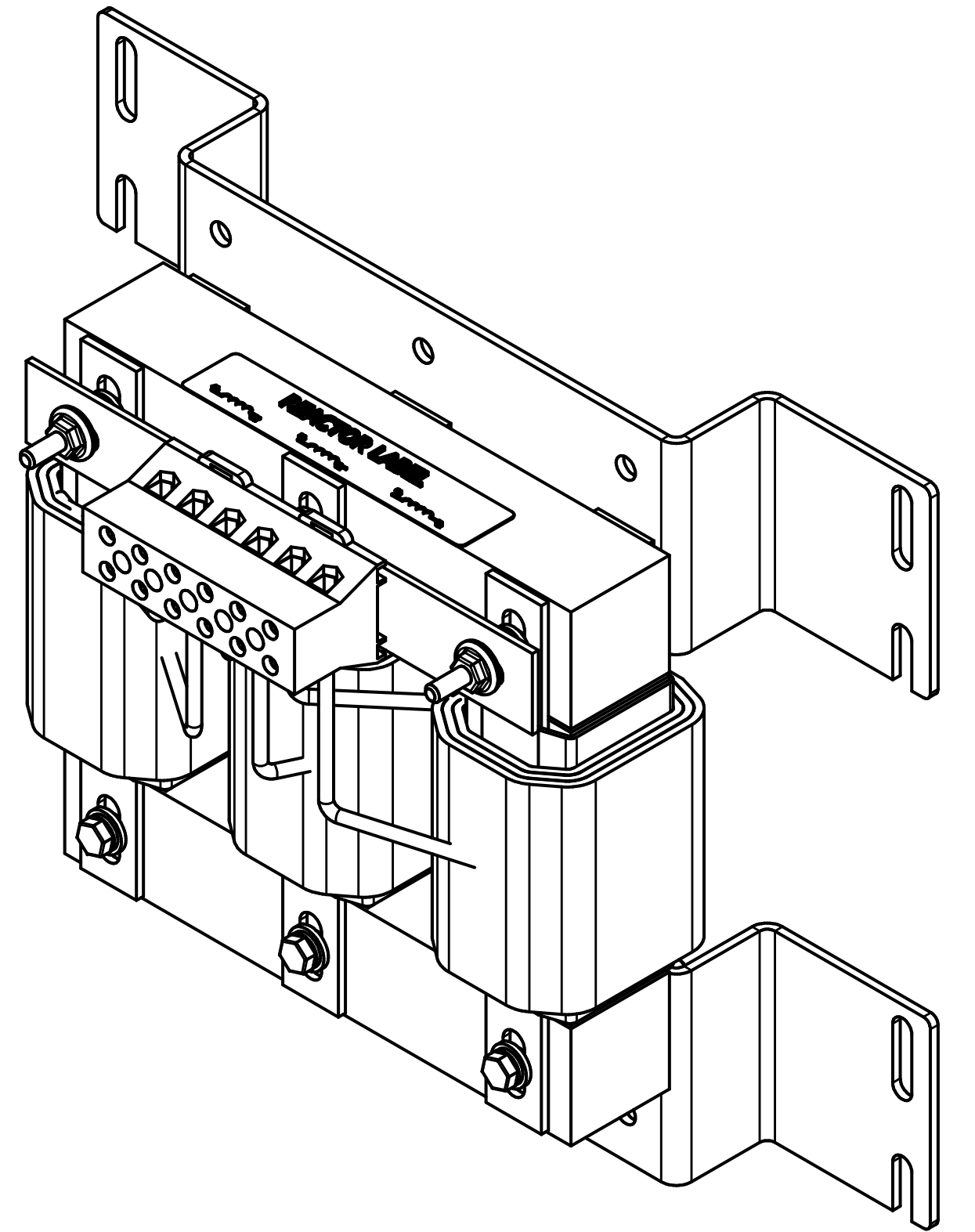
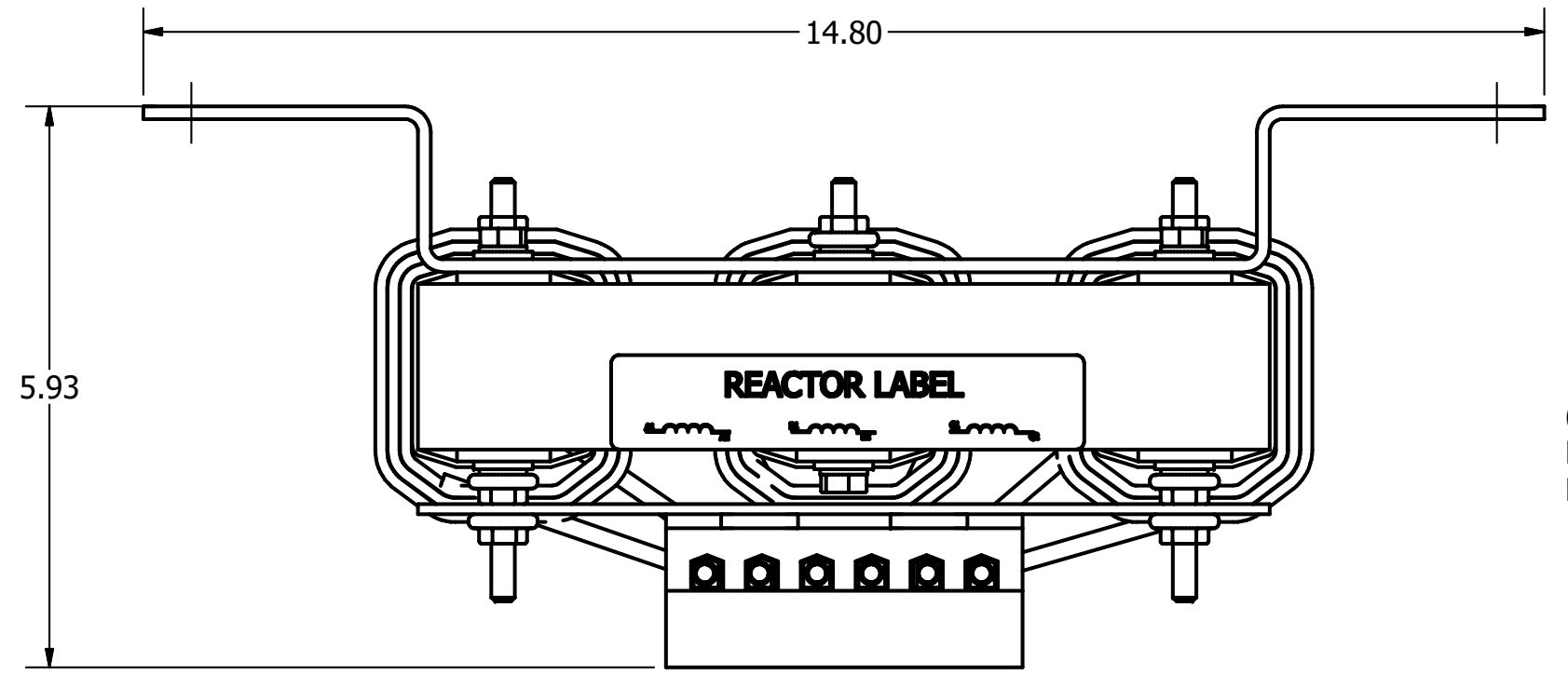

Customer Is Responsible For Installation to
 Meet All National And Local Electrical Codes.

Material(s) Shall be RoHS Compliant

TCI, LLC CLAIMS PROPRIETARY RIGHTS IN THE MATERIAL HEREIN DISCLOSED. IT IS SUPPLIED WITHOUT PREJUDICE TO ANY PATENT RIGHTS OF TCI AND MAY NOT BE REPRODUCED OR USED TO MANUFACTURE ANYTHING SHOWN THEREIN WITHOUT WRITTEN PERMISSION FROM TCI.				TOLERANCES (EXCEPT AS NOTED)	W132 N10611 Grant Drive Germantown, WI 53022 KTR15A65HG4, Wall Mounted, 28.70A, 3 Phase, 5th Tuning Inductor,
				DECIMAL	
				.XX ± .25 .XXX ± .10	
				FRACTIONAL ± 1/16	
A	AS DESIGNED	8/6/18	DSW	ANGULAR ± 1°	DRN BY: DSW DATE: 8/6/18 SCALE: 1/2 APRVD: [Signature] SIZE: C 107798DG SHT 1 OF 1
NO	REVISION	DATE	BY		