

TERMINAL BLOCKS 10mm²
TIGHTENING TORQUE 1.2...1.5 Nm

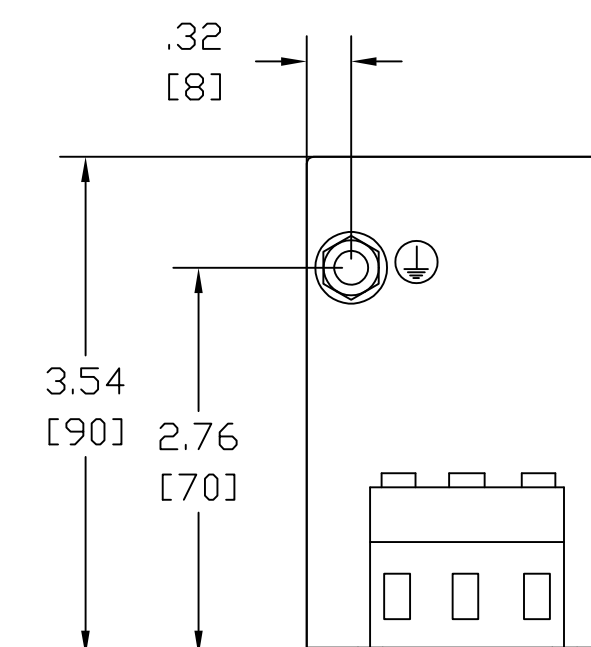
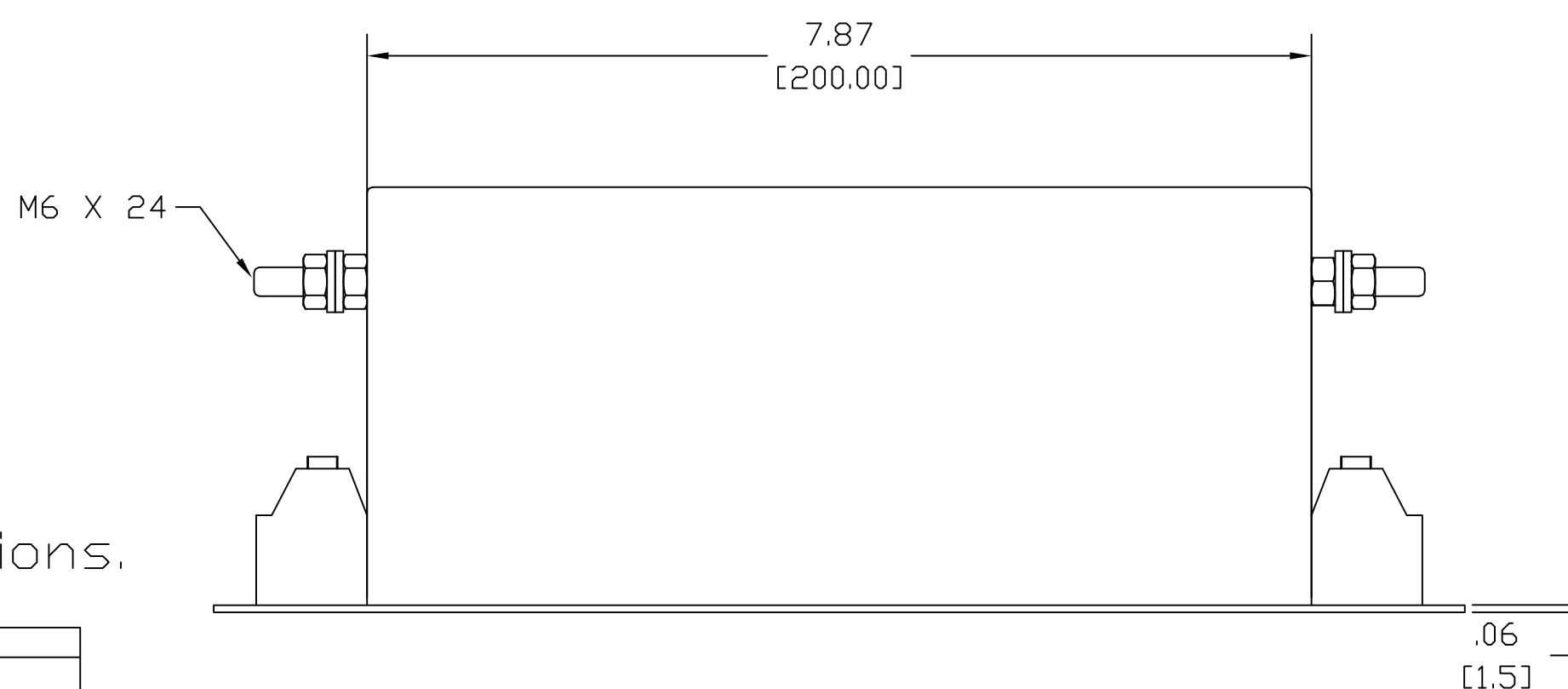
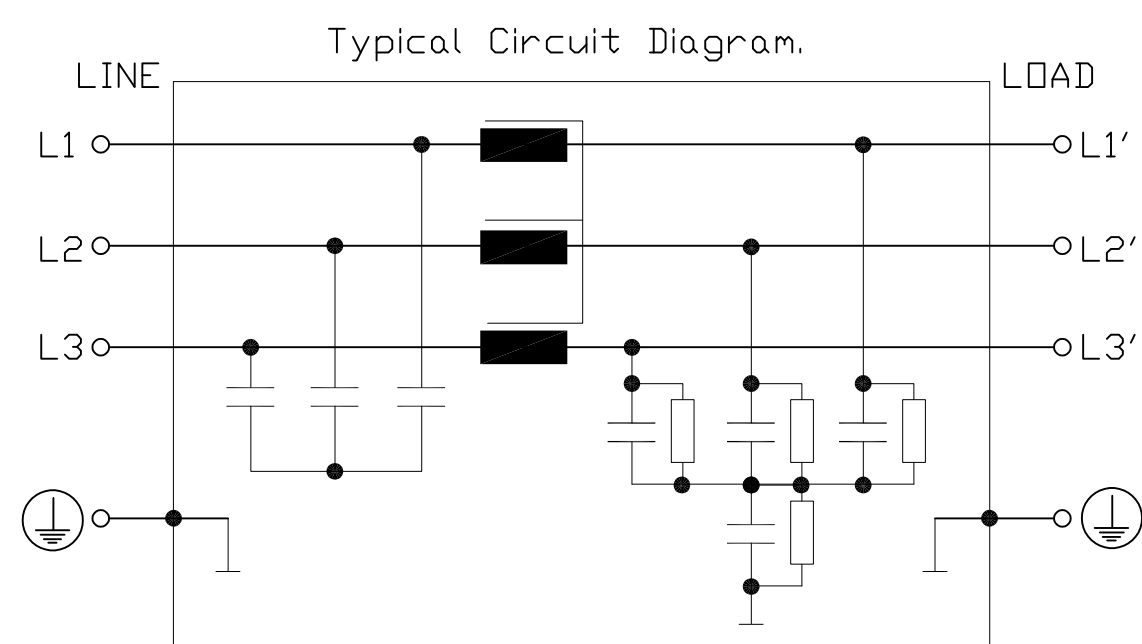

Technical data and measuring conditions.

Rated Voltage V_R	520/300 V AC, 50/60Hz.
Rated Current I_R	Referred to 40 °C ambient temperature
Test Voltage V_{test}	2236 V DC, 2 s (line/line) 2720 V DC, 2 s (line/case)
Overload Capability (thermal)	1.5 · I_R for 3 min per hour or 2.5 · I_R for 30 s per hour
Leakage Current I_{leak}	At 520 V AC, 50 Hz.
Climatic Category (IEC 60068-1)	25/100/21 (-25 °C/+100 °C/21 days damp heat test)
Approval Standards	EN 133200, UL 1283, CSA C22.2 No. 8
Approval Markings	UR, cUR

V_R AC V	I_R A	Terminal cross section mm ²	I_{leak} mA	$R_{typ.}$ m ohm	Approx. Weight kg. / lbs.
520/300	50	10	15	2	1.75 / 3.90

			TOLERANCES (EXCEPT AS NOTED)	W132 N10611 Grant Drive Germentown, WI 53022
			DECIMAL	
			.XX ± .02	KRF FILTER KRF0050ATB, 200-480V, 50A
			.XXX ± .01	
ECO 3959 ADDED	4/12/17	JRN	FRACTIONAL ± 1/32	DRN. BY DSW DATE 1/04/2010 DVG. NO. C KRF0050ATB
APPROVAL MARKINGS			ANGULAR ± 1/2°	SCALE TO FIT APRVD.
NO	REVISION	DATE	BY	SHT.1 of 1