

KPCUL020A60, 480V, 20kVar, 60HP.

APPROX. WEIGHT: 7LBS

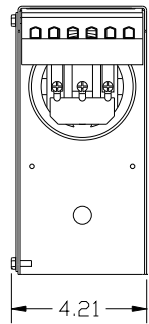

TORQUE(LB-IN)=CUSTOMER WIRE

35=1 AWG THRU 4 AWG

30=6 AWG THRU 14 AWG

25=16 AWG THRU 20 AWG

20=22 AWG

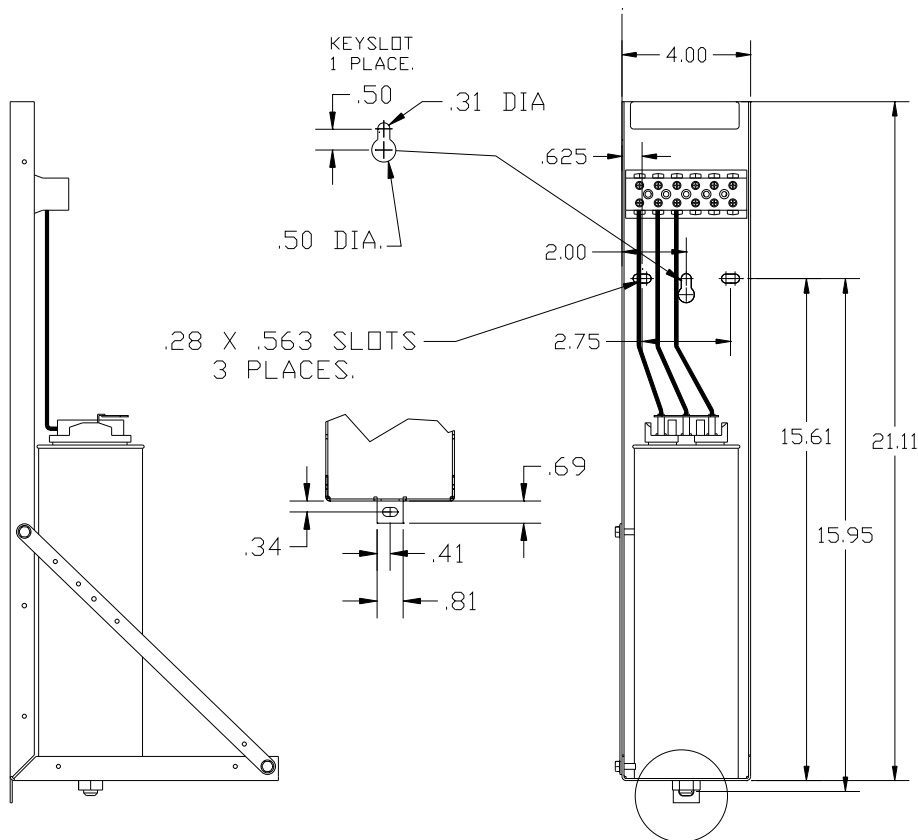
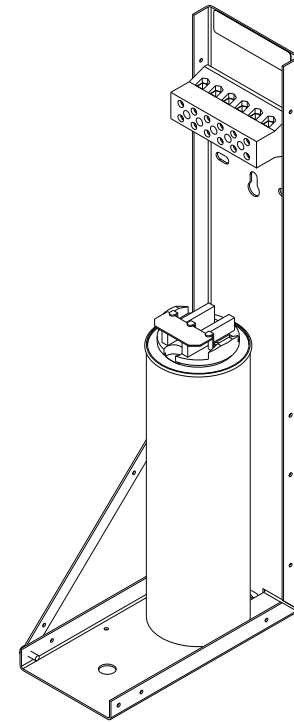

SEE  
DETAIL A

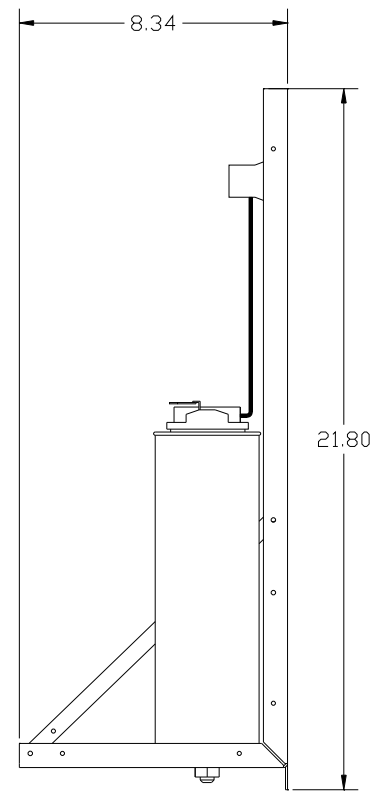

NOTE: 27908, Manual KPC Installation Guide  
MUST SHIP WITH EACH ASSEMBLY.

TCL, LLC CLAIMS PROPRIETARY RIGHTS IN THE MATERIAL HEREIN DISCLOSED. IT IS SUPPLIED WITHOUT PREJUDICE TO ANY PATENT RIGHTS OF TCL AND MAY NOT BE REPRODUCED OR USED TO MANUFACTURE ANYTHING SHOWN THEREIN WITHOUT WRITTEN PERMISSION FROM TCL.				TOLERANCES (EXCEPT AS NOTED): DECIMAL	W132 N10611 Grant Drive Germantown, WI 53022	
				.XX ± .03		
	C	3093 CAP CHG	5/9/14	BMZ	.XXX ± .01	KPCUL020A60, 60HP, 20kVar PANELIZED CAPS
	B	2805 UPDATE BRACKET	1/9/12	DSW	FRACTIONAL ± 1/32	
	A	AS BUILT	9/1/11	DSW	ANGULAR ± 1/2°	
NO	REVISION	DATE	BY	SCALE	DRN BY: DSW    DATE: 8/22/11    DWG. NO.: 104790DG TO FIT    SIZE:    C    SHT. 1 OF 1	