

CATALOG NO	VOLTAGE	NEC MOTOR HP	NEC MOTOR CURRENT	WATTS LOSS	APPROX. WEIGHT-LBS	TORQUE (LB-IN)
KDRULA4LE3R	480	7.5	11.0	40	19	10

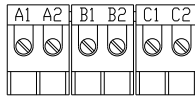
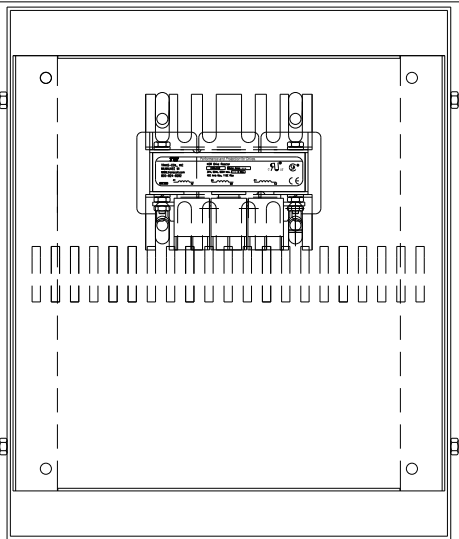

TERMINAL BLK MARKING

NOTE: A1, A2, B1, B2, C1, C2, MAKING'S ON TERMINAL BLOCK FOR REFERENCE ONLY.

NOTE 1: WATTS LOSS WILL VARY DUE TO FUNDAMENTAL FREQUENCY, CARRIER FREQUENCY AND OTHER SYSTEM CHARACTERISTICS.

KDR DRIVE REACTORS COMPLY WITH THE THERMAL AND ALTITUDE STANDARDS SET FORTH BY NEMA ST20-1992..

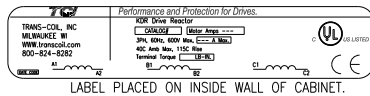

LABEL PLACED ON INSIDE WALL OF CABINET.

NEC MOTOR CURRENTS SHOWN IN THE 208/240 VOLT CHART ARE BASED ON HORSEPOWER AT 208 VOLT. 575/600 VOLT CHART USE THE 575 VOLT CURRENT RATING.

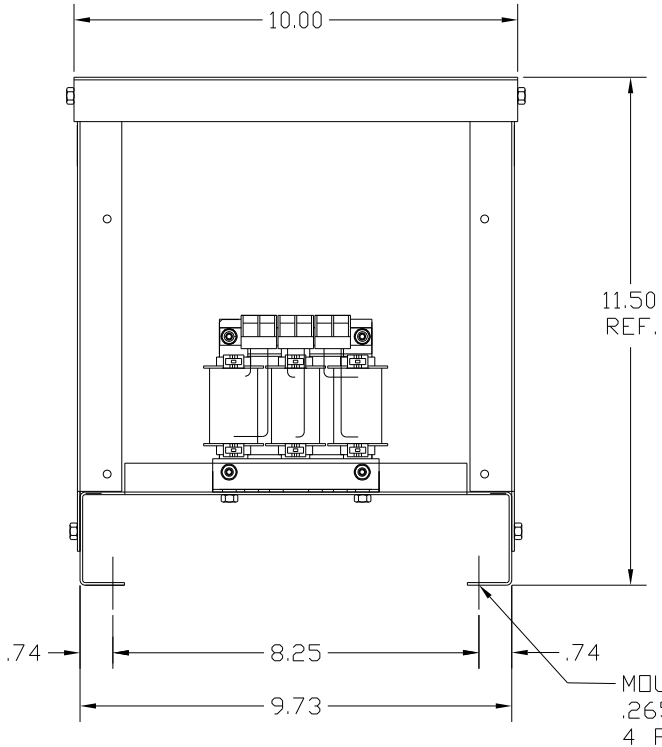

MOUNTING .265 DIA HOLES 4 PLACES

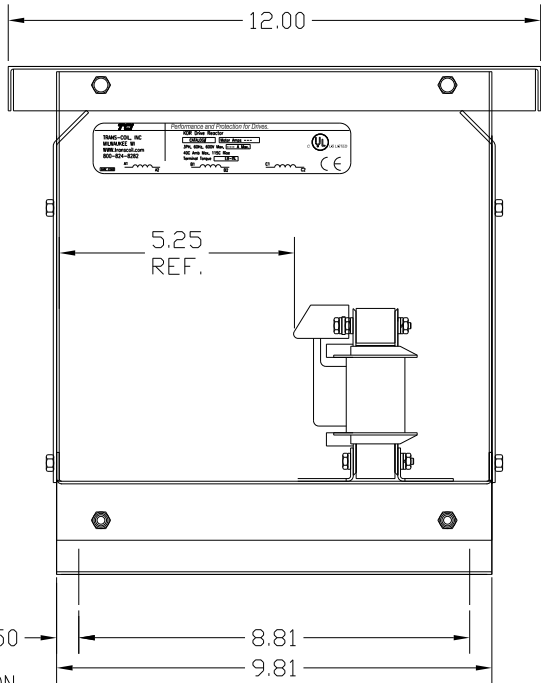
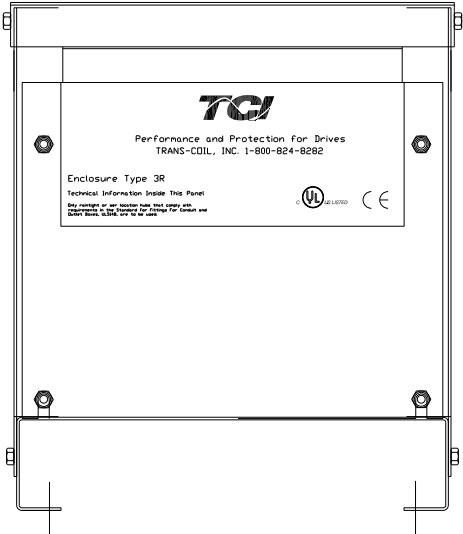

CUSTOMER IS RESPONSIBLE FOR INSTALLATION TO MEET ALL NATIONAL AND LOCAL ELECTRICAL CODES.

NOTE: USE ONLY HUBS OR FITTINGS THAT COMPLY WITH UL514B FOR TYPE 3R ENCLOSURES.

FINISH:
 VENDOR - LILLY POWDER COATINGS, INC.
 PRODUCT CODE - 312E
 COLOR - PEBBLE GRAY
 POWDER TYPE - POLYESTER-POLYURETHANE
 PAINT SUITABLE FOR OUTDOOR APPLICATION PER UL TYPE 3R AND APPLIED PER A UL ACCEPTED DTVV2 COATING PROGRAM.

				7878 N. 86th STREET MILWAUKEE, WI 53224	
				KDR DRIVE REACTOR 480V, ENCLOSED, TYPE 3R	
NO		REVISION	DATE	BY	TOLERANCES (EXCEPT AS NOTED): DECIMAL .XX ± .03 .XXX ± .01 FRACTIONAL ± 1/32 ANGULAR ± 1/2°
					DRN. BY DSW DATE 9/20/04 DWG. NO. B SCALE APRVD. KDRULA4LE3RDRG SH. 1 OF 1