

CATALOG NO	VOLTAGE	NEC MOTOR HP	NEC MOTOR CURRENT	WATTS LOSS	APPROX. WEIGHT-LBS	TORQUE (LB-IN)
KDRULA49LE3R	575/600	10.0	11	43.8	19	10

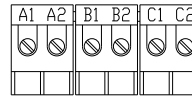

TERMINAL BLK MARKING

NOTE: A1, A2, B1, B2, C1, C2, MARKING'S ON TERMINAL BLOCK FOR REFERENCE ONLY.

NOTE 1: WATTS LOSS WILL VARY DUE TO FUNDAMENTAL FREQUENCY, CARRIER FREQUENCY AND OTHER SYSTEM CHARACTERISTICS.

KDR DRIVE REACTORS COMPLY WITH THE THERMAL AND ALTITUDE STANDARDS SET FORTH BY NEMA ST20-1992..

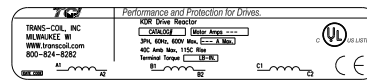

LABEL PLACED ON INSIDE WALL OF CABINET.

NEC MOTOR CURRENTS SHOWN IN THE 208/240 VOLT CHART ARE BASED ON HORSEPOWER AT 208 VOLT. 575/600 VOLT CHART USE THE 575 VOLT CURRENT RATING.

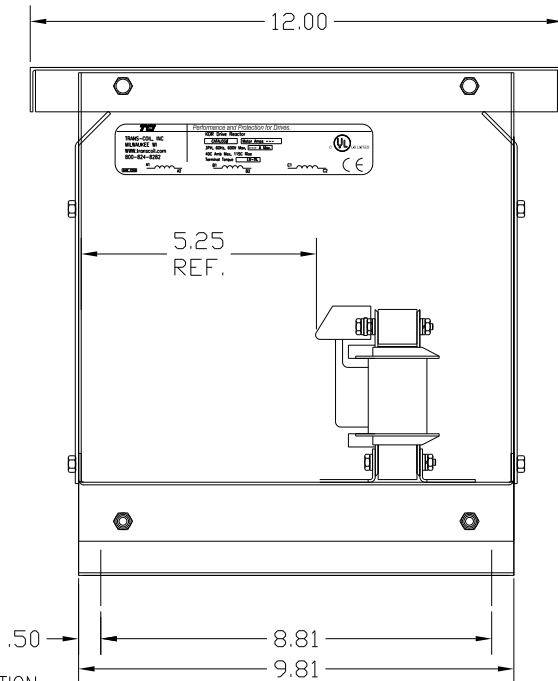
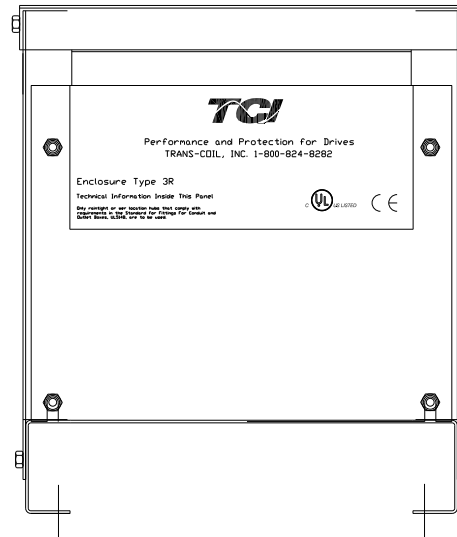
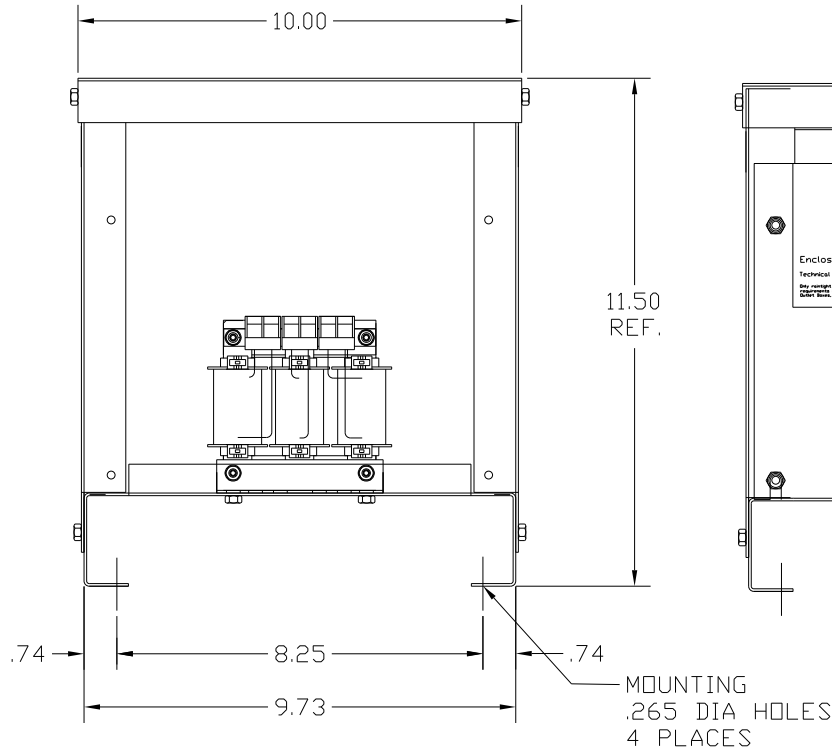

CUSTOMER IS RESPONSIBLE FOR INSTALLATION TO MEET ALL NATIONAL AND LOCAL ELECTRICAL CODES.

NOTE: USE ONLY HUBS OR FITTINGS THAT COMPLY WITH UL514B FOR TYPE 3R ENCLOSURES.

FINISH:
VENDOR - LILLY POWDER COATINGS, INC.
PRODUCT CODE - 312E
COLOR - PEBBLE GRAY
POWDER TYPE - POLYESTER-POLYURETHANE

PAINT SUITABLE FOR OUTDOOR APPLICATION PER UL TYPE 3R AND APPLIED PER A UL ACCEPTED DTVV2 COATING PROGRAM.

NO	REVISION	DATE	BY	TOLERANCES (EXCEPT AS NOTED): DECIMAL .XX ± .03 .XXX ± .01 FRACTIONAL ± 1/32 ANGULAR ± 1/2°	 7878 N. 86th STREET MILWAUKEE, WI 53224 KDR DRIVE REACTOR 575V, ENCLOSED, TYPE 3R DRN. BY DSW DATE 9/20/04 DWG. NO. KDRULA49LE3R DG SCALE APRVD. SHT. 1 of 1