

TERMINAL BLK MARKING

NOTE: A1, A2, B1, B2, C1, C2,
MARKING'S ON TERMINAL BLOCK
FOR REFERENCE ONLY.



LABEL PLACED ON INSIDE WALL OF CABINET.

CATALOG NO	VOLTAGE	NEC MOTOR HP	NEC MOTOR CURRENT	WATTS LOSS	APPROX. WEIGHT-LBS	TORQUE (LB-IN)
KDRULA3LE3R	480	5.0	7.6	49	19	10

NOTE 1: WATTS LOSS WILL VARY DUE TO FUNDAMENTAL FREQUENCY,
CARRIER FREQUENCY AND OTHER SYSTEM CHARACTERISTICS.
KDR DRIVE REACTORS COMPLY WITH THE THERMAL AND
ALTITUDE STANDARDS SET FORTH BY NEMA ST20-1992..

NEC MOTOR CURRENTS SHOWN IN THE 208/240 VOLT CHART
ARE BASED ON HORSEPOWER AT 208 VOLT. 575/600 VOLT
CHART USE THE 575 VOLT CURRENT RATING.

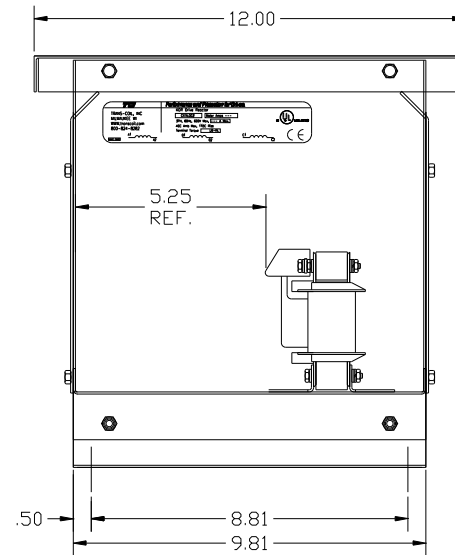
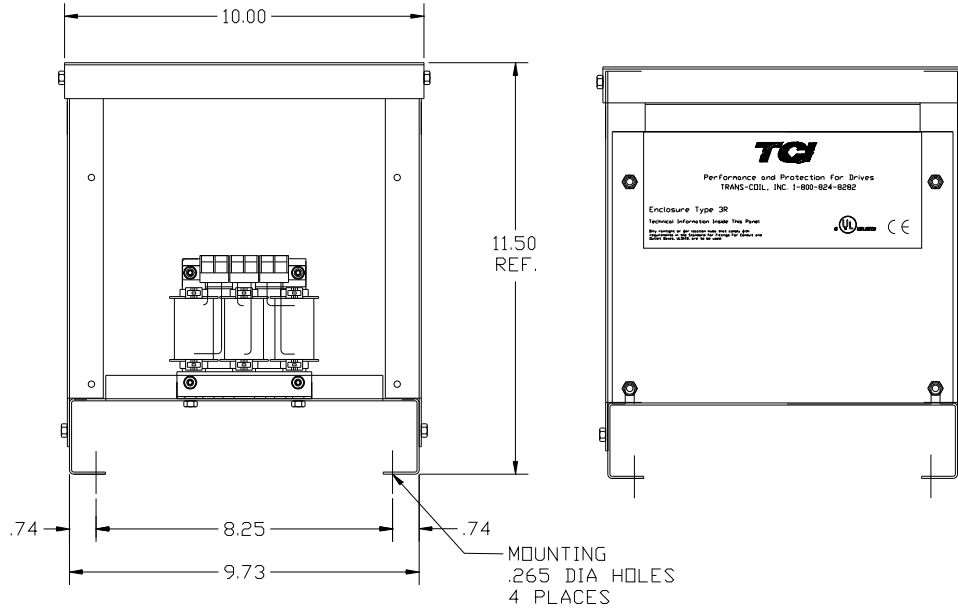

CUSTOMER IS RESPONSIBLE FOR INSTALLATION
TO MEET ALL NATIONAL AND LOCAL ELECTRICAL CODES.

NOTE: USE ONLY HUBS OR FITTINGS THAT COMPLY
WITH UL514B FOR TYPE 3R ENCLOSURES.

<p>TCL, LLC CLAIMS PROPRIETARY RIGHTS IN THE MATERIAL HEREIN DISCLOSED. IT IS SUPPLIED WITHOUT PREJUDICE TO ANY PATENT RIGHTS OF TCL AND MAY NOT BE REPRODUCED OR USED TO MANUFACTURE ANYTHING SHOWN THEREIN WITHOUT WRITTEN PERMISSION FROM TCL.</p>					<p>TOLERANCES (EXCEPT AS NOTED):</p> <p>DECIMAL</p> <p>.XX ± .03</p> <p>.XXX ± .01</p> <p>FRACTIONAL</p> <p>± 1/32</p> <p>ANGULAR</p> <p>± 1/2°</p>	<p>TCL® W132 N10611 Grant Drive Germantown, WI 53022</p> <p>KDR DRIVE REACTOR 480V, ENCLOSED, TYPE 3R</p>	DRN BY	DATE	DWG. NO.
	NO	REVISION	DATE	BY	SCALE		SIZE	D	

KDRULA3LE3R
SHT. 1 of 1