

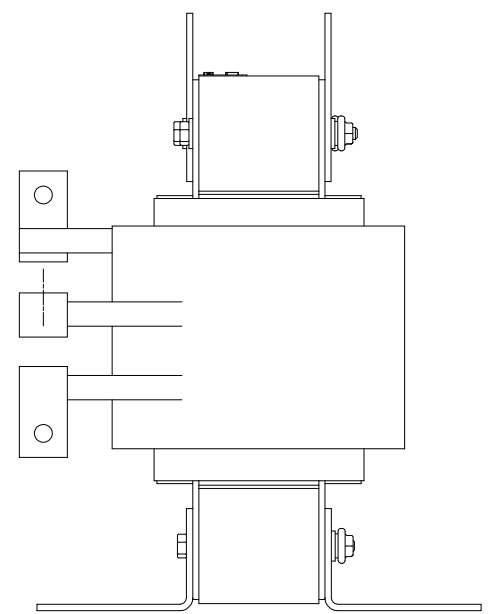

0.38 DIA HOLES

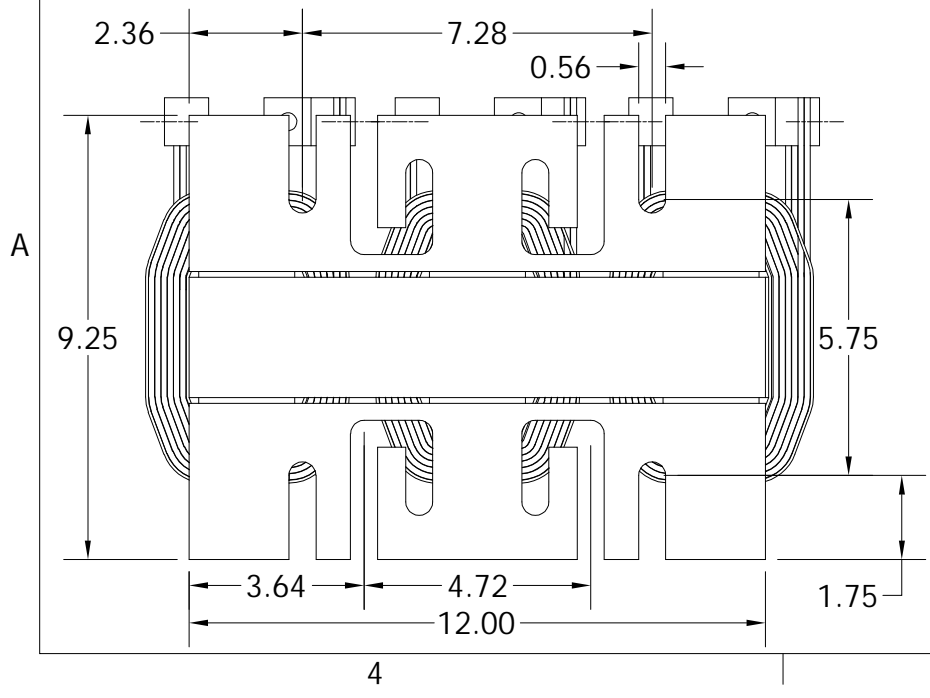
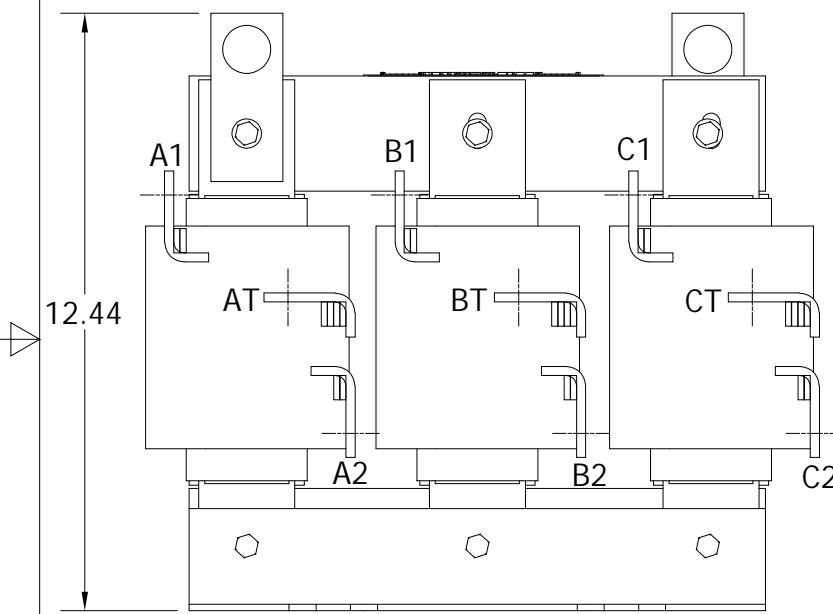
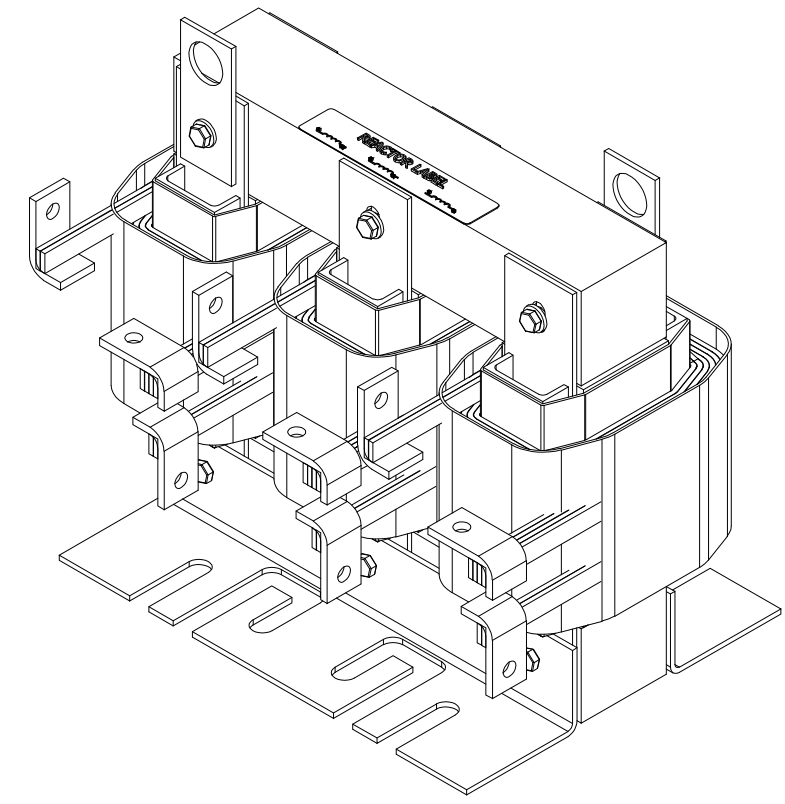

HP	CATALOG NO	RATED AMPS(A)	MAX AMPS(A)	APPROX WT-LBS
150	KDRL7TT	145	180	125

480V, 60 HZ., 612uH



				TOLERANCES (EXCEPT AS NOTED)	 W132 N10611 Grant Drive Germantown, WI 53022	
				DECIMAL	<b>KDRL7TT</b> <b>150 HP, HGP FILTER, 180 AMPS MAX.</b>	
				.XX ± .25 .XXX ± .10		
				FRACTIONAL	DRN. BY	DATE: 1/04/16
				± 1/16	DSW	106815DG
				ANGULAR	SCALE: 1/4	APRVD:
				± 1°		SIZE B
A	AS DESIGNED	1/04/16	DSW	SHT.1 OF 1		
NO	REVISION	DATE	BY			