

HP	CATALOG NO	__AMPS(A)	APPROX WT-LBS
100	KDRJ2TT	124	80

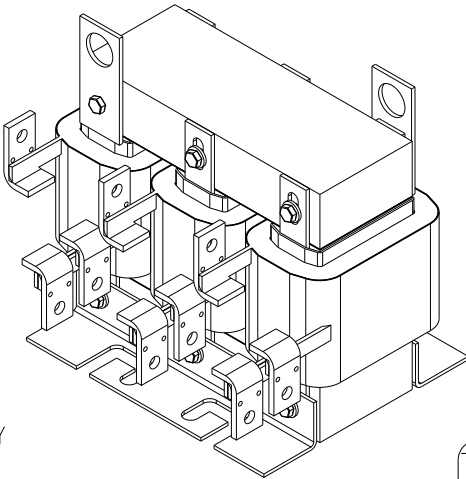

A1, AT, A2, B1, BT, B2, C1, CT, C2, MARKINGS FOR REFERENCE ONLY

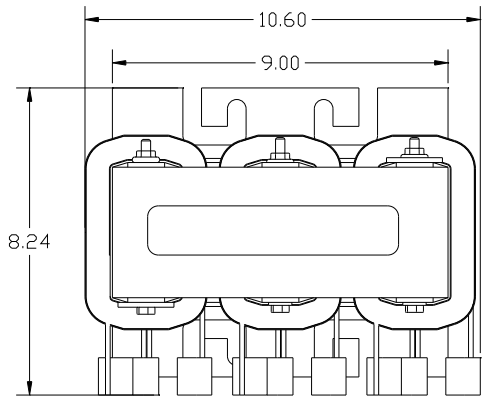
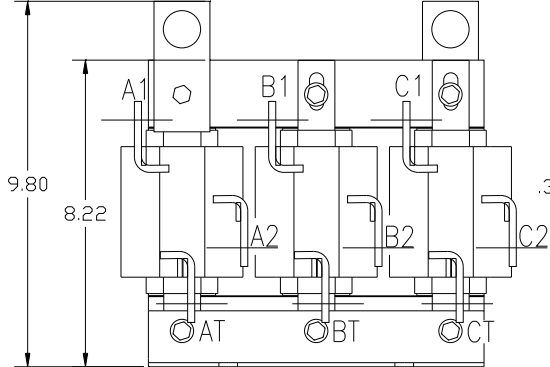

.38 DIA HOLES
9 PLACES.

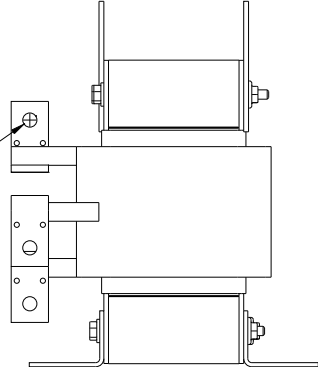

TCL TRANS-COIL, INC MILWAUKEE, WI WWW.transcoil.com 800-824-8282	KDR Drive Reactor REACTOR Motor Amps <input type="text"/> Max 3PH, 60Hz, 600V Max. <input type="text"/> Size 40C Amb Max, 155C Rise	

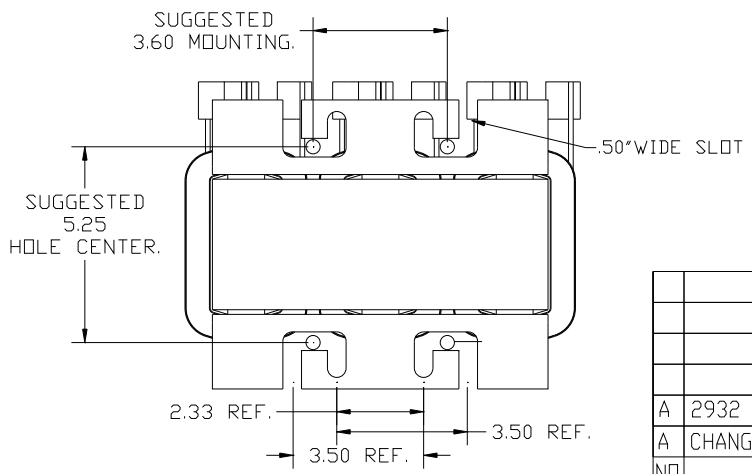

				TOLERANCES (EXCEPT AS NOTED): DECIMAL
				.XX ± .03
				.XXX ± .01
				FRACTIONAL ± 1/32
				ANGULAR ± 1/2°
A	2932 CHANGE TAP TERM			
A	CHANGE COIL TPL WAS 5	8/1/2013	DSW	
NO	REVISION	DATE	BY	

	7878 N. 86th STREET MILWAUKEE, WI 53224
	KDRJ2TT, 100HP HGP FILTER REACTOR
DRN BY DSW SCALE TO FIT	DATE 7/5/2013 APRVD
DWG NO. C	105297DG SHT. 1 OF 1