

CATALOG NO	VOLTAGE	NEC MOTOR HP	NEC MOTOR CURRENT	WATTS LOSS	APPROX. WEIGHT-LBS	TORQUE (LB-IN)
KDRA50LDR	575/600	1.0	1.70	12	4	10

NEC MOTOR CURRENTS SHOWN IN THE 208/240 VOLT CHART ARE BASED ON HORSE POWERS AT 208 VOLT. 575/600 VOLT CHART USE THE 575 VOLT CURRENT RATING.

KDR DRIVE REACTORS COMPLY WITH THE THERMAL AND ALTITUDE STANDARDS SET FORTH BY NEMA ST20-1992..

TCI Performance and Protection for Drives.

TRANS-COIL, INC
MILWAUKEE, WI
WWW.transcoil.com
800-824-8282

KLR Series Line Reactor
CATALOG#
3PH, 60Hz, 600V Max, --- Amps
40C Amb Max, 115C Rise

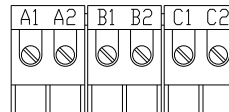

NOTE: A1, A2, B1, B2, C1, C2, ON TERMINAL BLOCK FOR REFERENCE ONLY.

BLOCK WIRE RANGE FOR REACTOR AND TIGHTENING TORQUE.	#12-#18 AWG 10 LB-IN
---	-------------------------

TCI'S DIN RAIL MOUNTED REACTORS FIT STANDARD 35mm DIN RAIL. TCI'S MINIMUM RECOMMENDATION IS TO USE: HIGH PROFILE STANDARD 35mm STEEL RAIL OR HEAVY DUTY STANDARD 35mm STEEL RAIL.

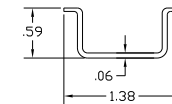

STANDARD STEEL HIGH PROFILE DIN RAIL.

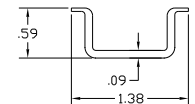

HEAVY DUTY STEEL DIN RAIL.

TCI RECOMMENDS TAKING PRECAUTIONS WHEN SHIPPING MOUNTED REACTORS.

NOTE: CUSTOMER CAN CHANGE MOUNTED REACTOR, FROM VERTICAL TO HORIZONTAL ON DIN BRACKET.

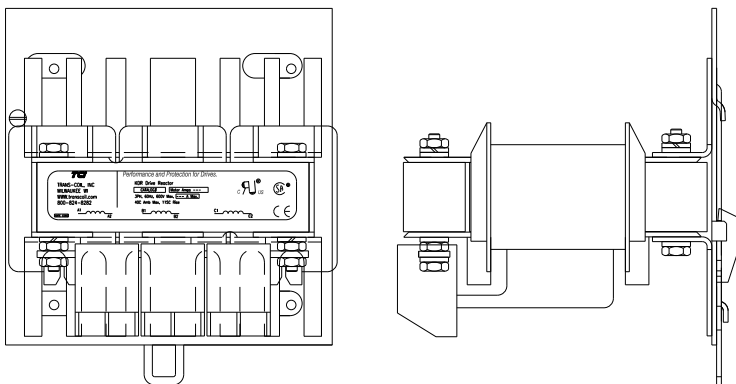

				TOLERANCES (EXCEPT AS NOTED)		7878 N. 86th STREET MILWAUKEE, WI 53224	
				DECIMAL			
				.XX ± .03 .XXX ± .01			
				FRACTIONAL ± 1/32			
				ANGULAR ± 1/2°		DRN BY DSW DATE 11/29/2011 DWG NO KDRA50LDRDG SCALE NONE APPRVD C SHT. 1 OF 1	
NO	REVISION	DATE	BY				