

Unit Specifications					
kVar	Harmonic	Volt	HZ.	Phase	HP
50	5TH	480	60	3	300

TCI Part Number	Option	Weight	Schematic
HGL0300AW1S0000	Standard	630lbs	30586-1
HGL0300AW1C0000	Contactors	640lbs	30586

See IOM Manual For Wire Range
And Tightening Torque.

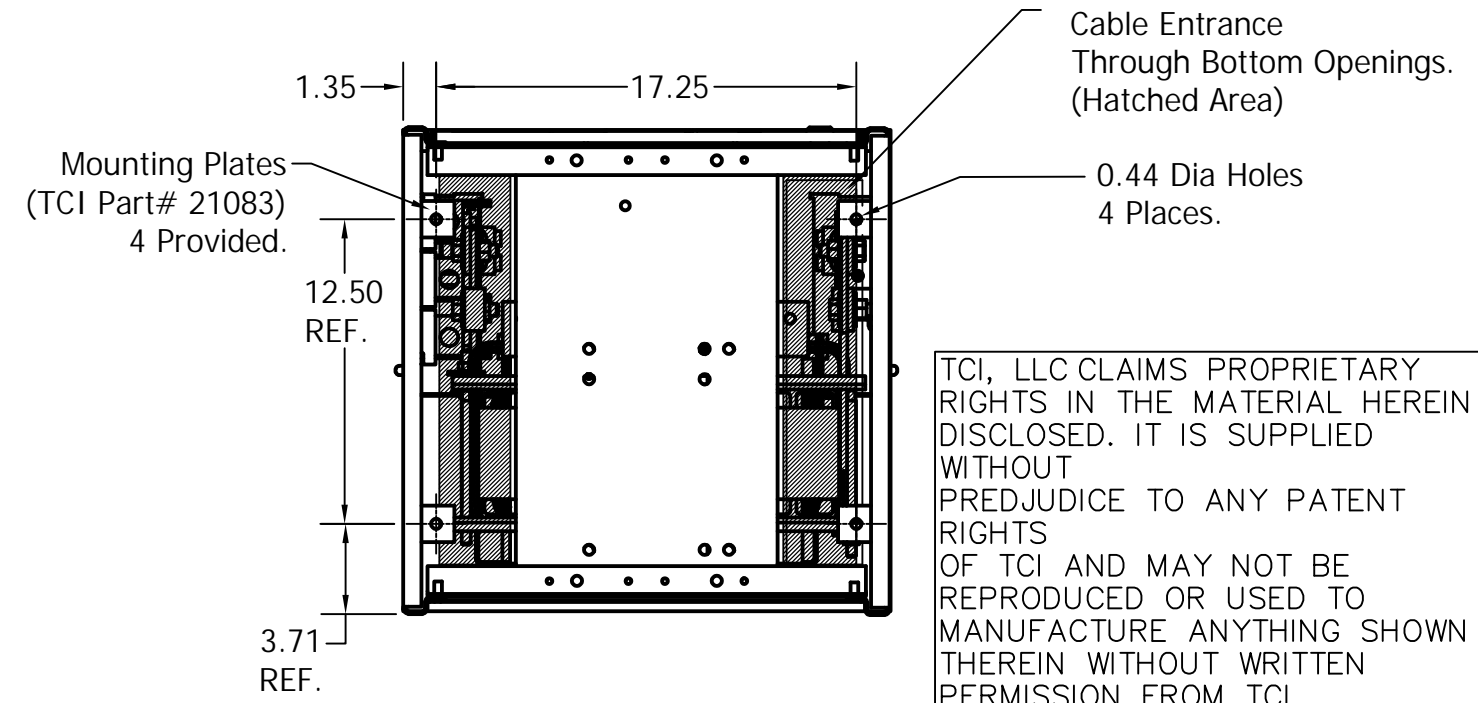
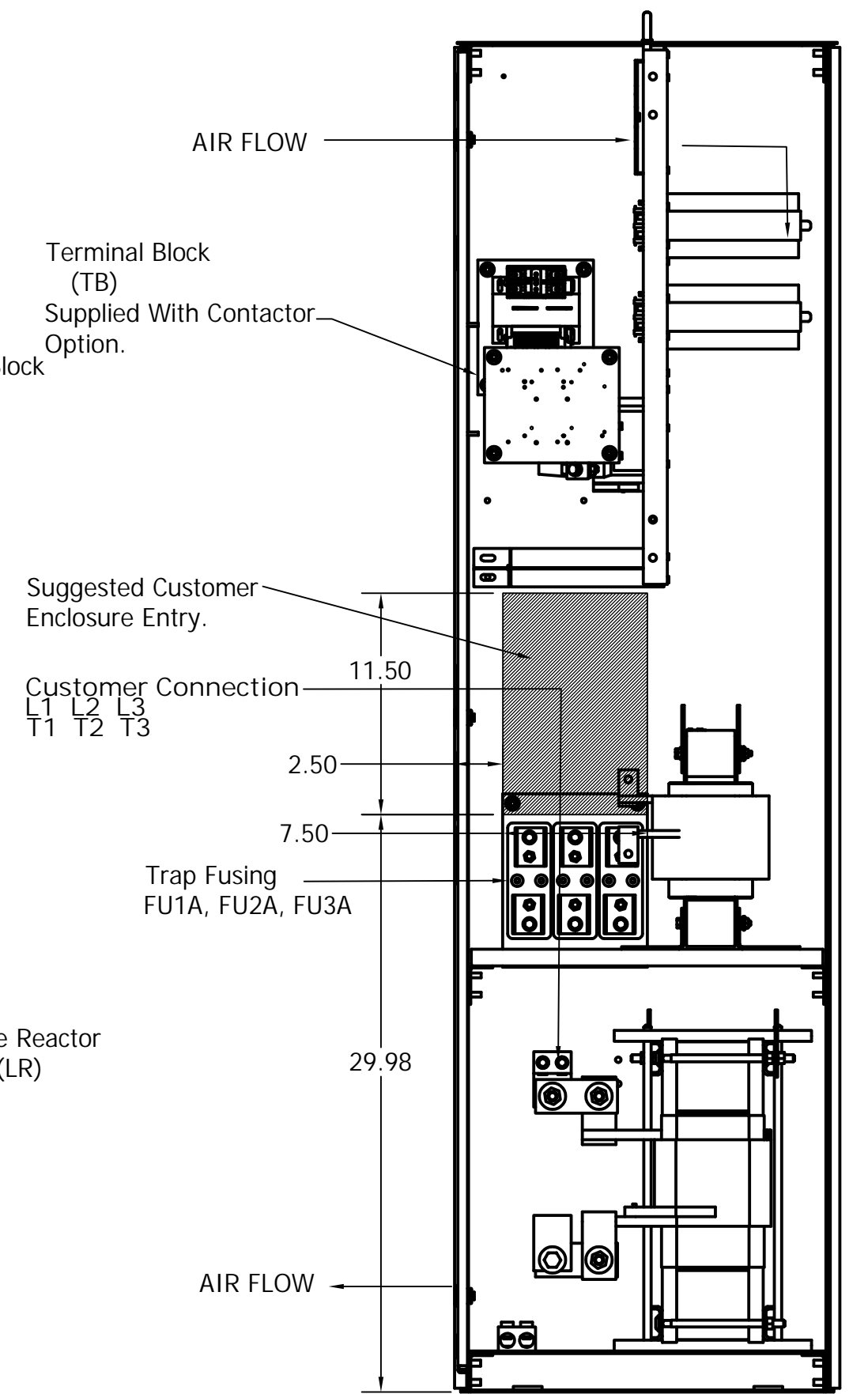
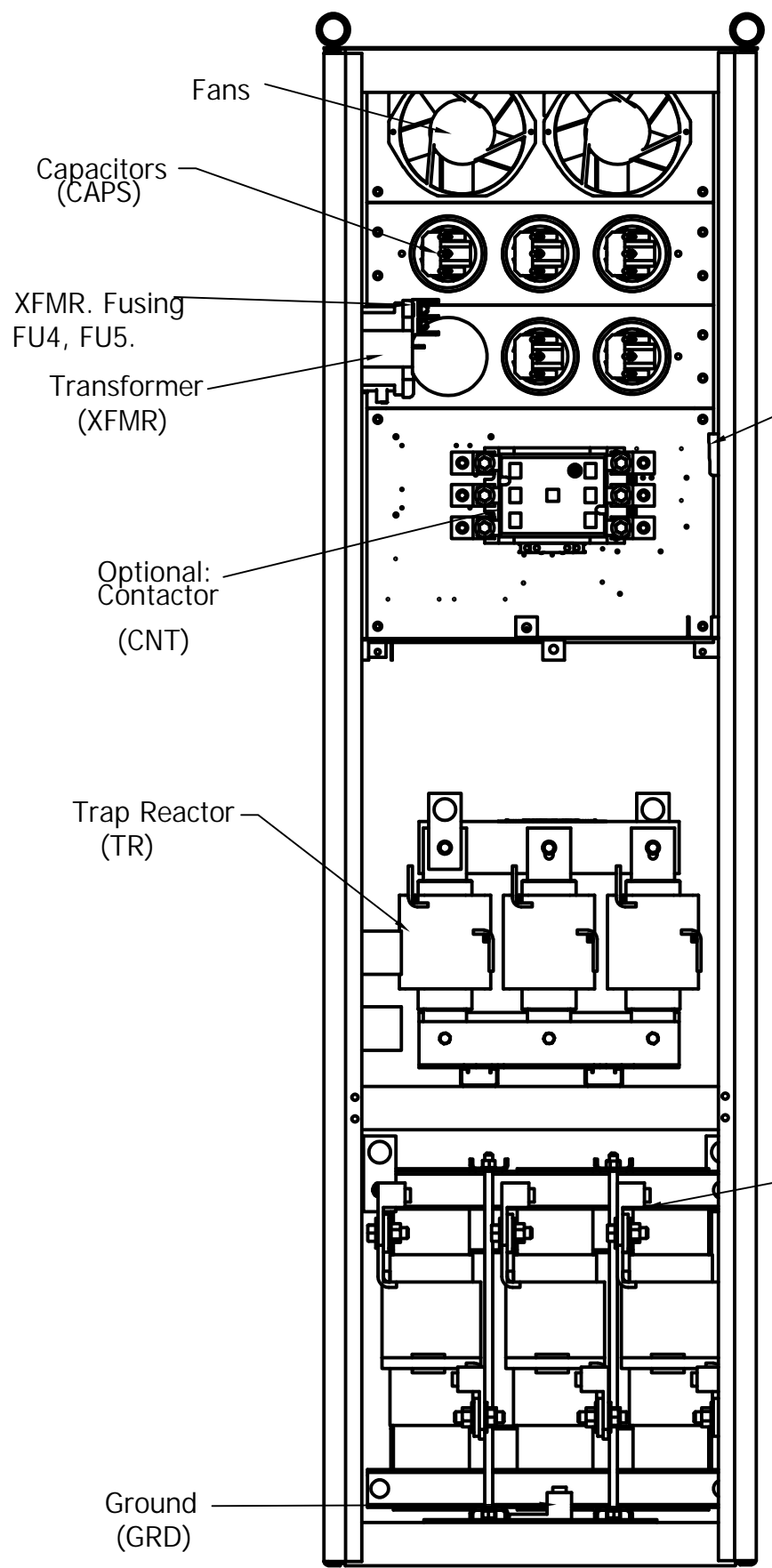
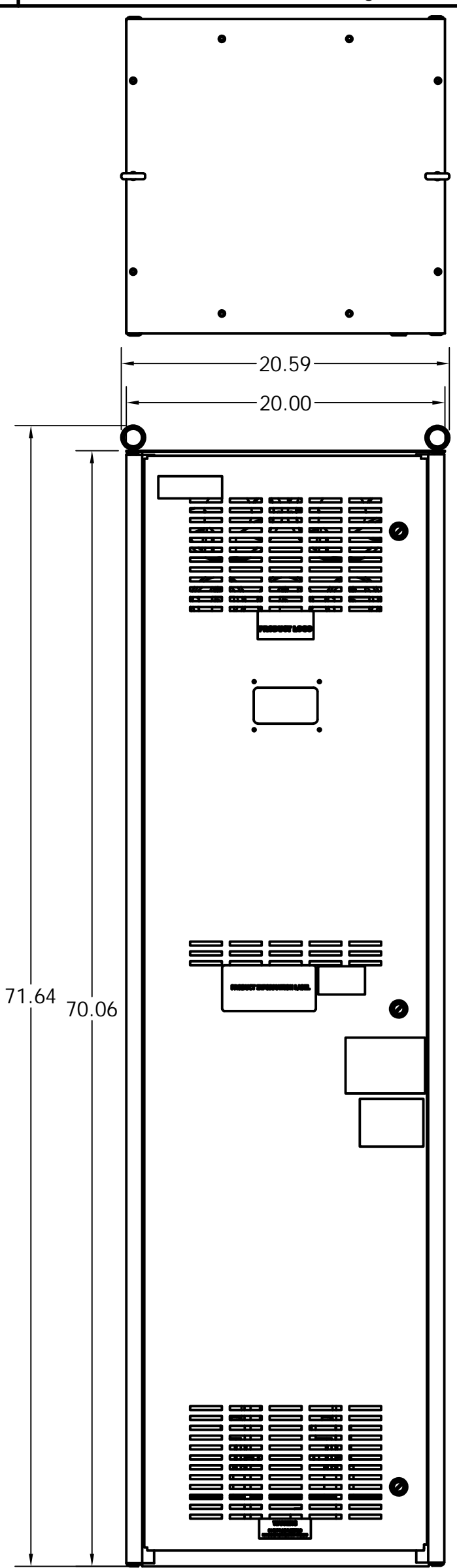
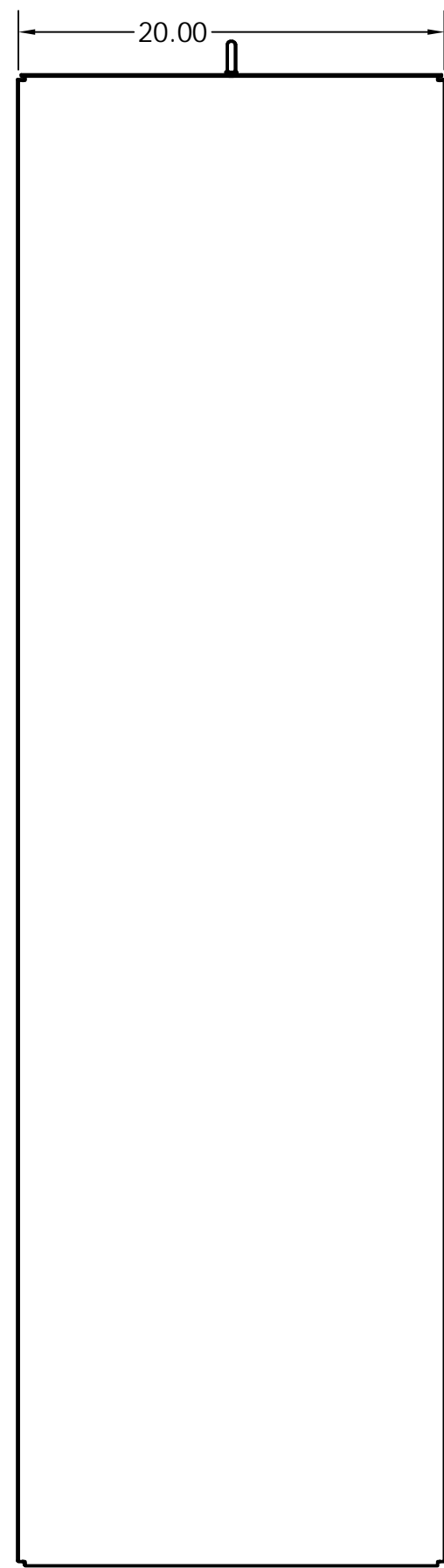

CUSTOMER IS RESPONSIBLE FOR INSTALLATION
TO MEET ALL NATIONAL AND LOCAL ELECTRICAL CODES.

Material(s) Shall be RoHS Compliant

TCI, LLC CLAIMS PROPRIETARY RIGHTS IN THE MATERIAL HEREIN DISCLOSED. IT IS SUPPLIED WITHOUT PREDJUDICE TO ANY PATENT RIGHTS OF TCI AND MAY NOT BE REPRODUCED OR USED TO MANUFACTURE ANYTHING SHOWN THEREIN WITHOUT WRITTEN PERMISSION FROM TCI.

TOLERANCES (EXCEPT AS NOTED)			
DECIMAL			
.XX	+/-	.25	
.XXX	+/-	.12	
FRACTIONAL			
+/-	1/16		
ANGULAR			
+/-	1°		

NO	REVISION	DATE	BY
A	AS DESIGNED	4/3/17	DSW

TCI® W132 N10611 Grant Drive
Germantown, WI 53022

HGL0300AW1C0000, 480V, 300HP, 3 Phase
HGL0300AW1S0000, 480V, 300HP, 3 Phase
60 Hz, Type 1, Low C, Passive Harmonic Filter

JRN. BY: DSW DATE: 4/3/17 DWG. No.: 107023DG
SCALE: 1/8 APRVD.

SHEET 1 OF 1