

Unit Specifications					
kVar	Harmonic	Volt	HZ.	Phase	HP
10	5TH	600	60	3	60
TCI Part Number		Option	Weight	Schematic	
HGL0060CW1S0000		Standard	200lbs	30807-1	
HGL0060CW1C0000		Contactora	205lbs	30807	

See IOM Manual For Wire Range
And Tightening Torque.

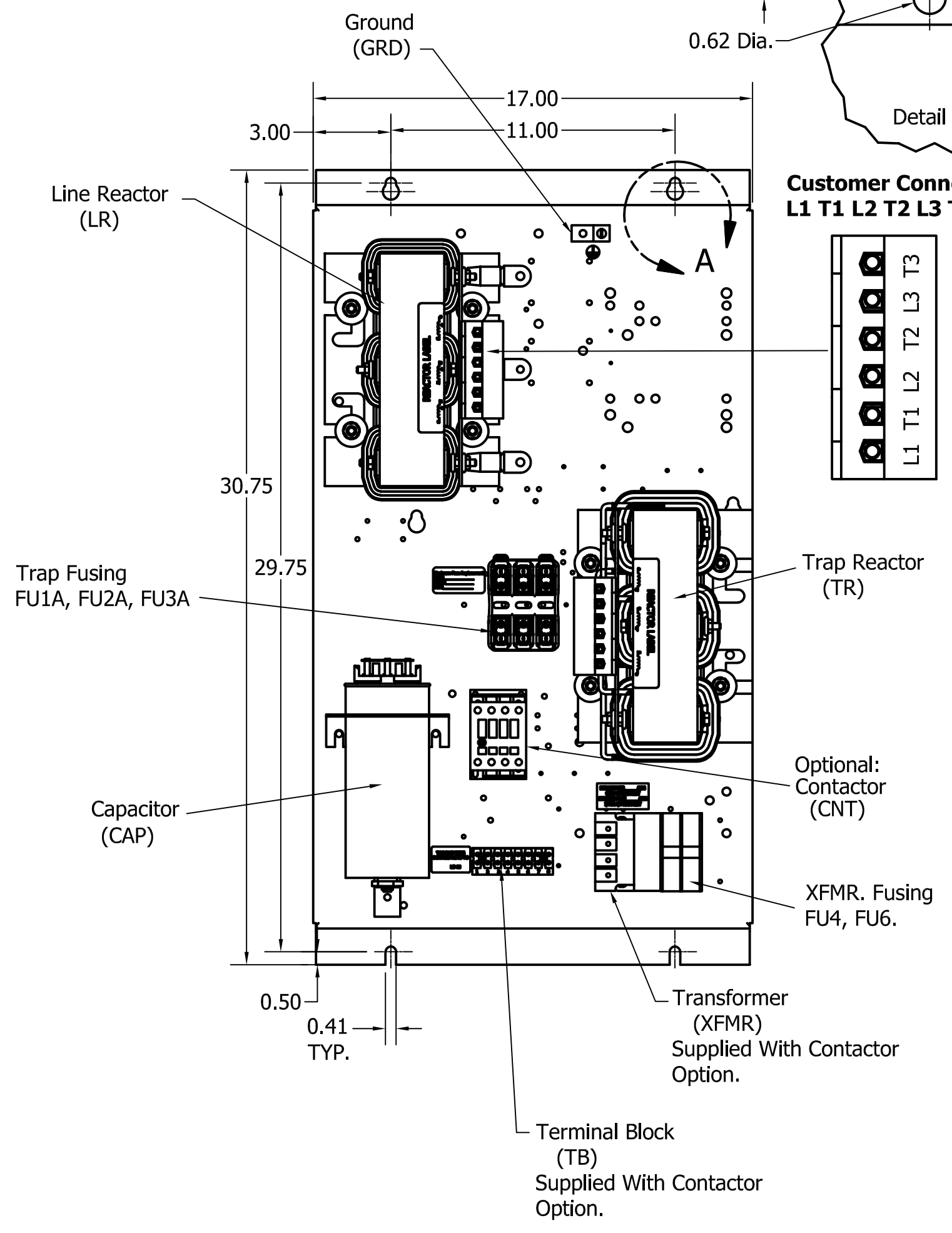

Customer Connection
L1 T1 L2 T2 L3 T3

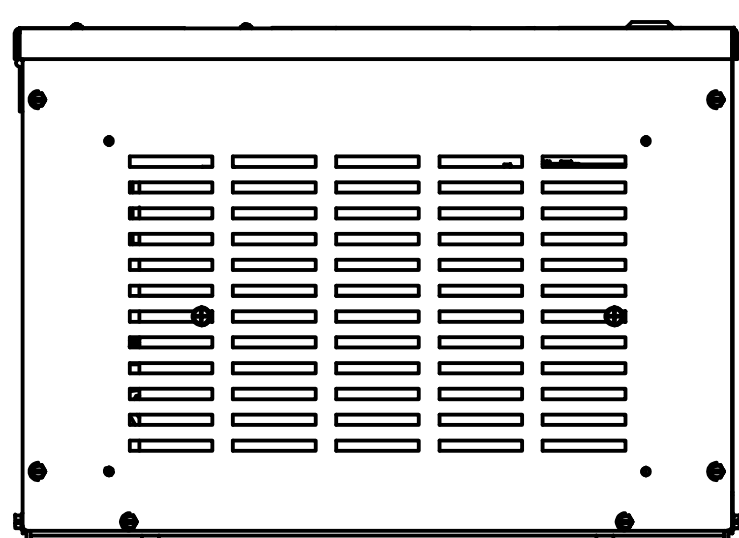
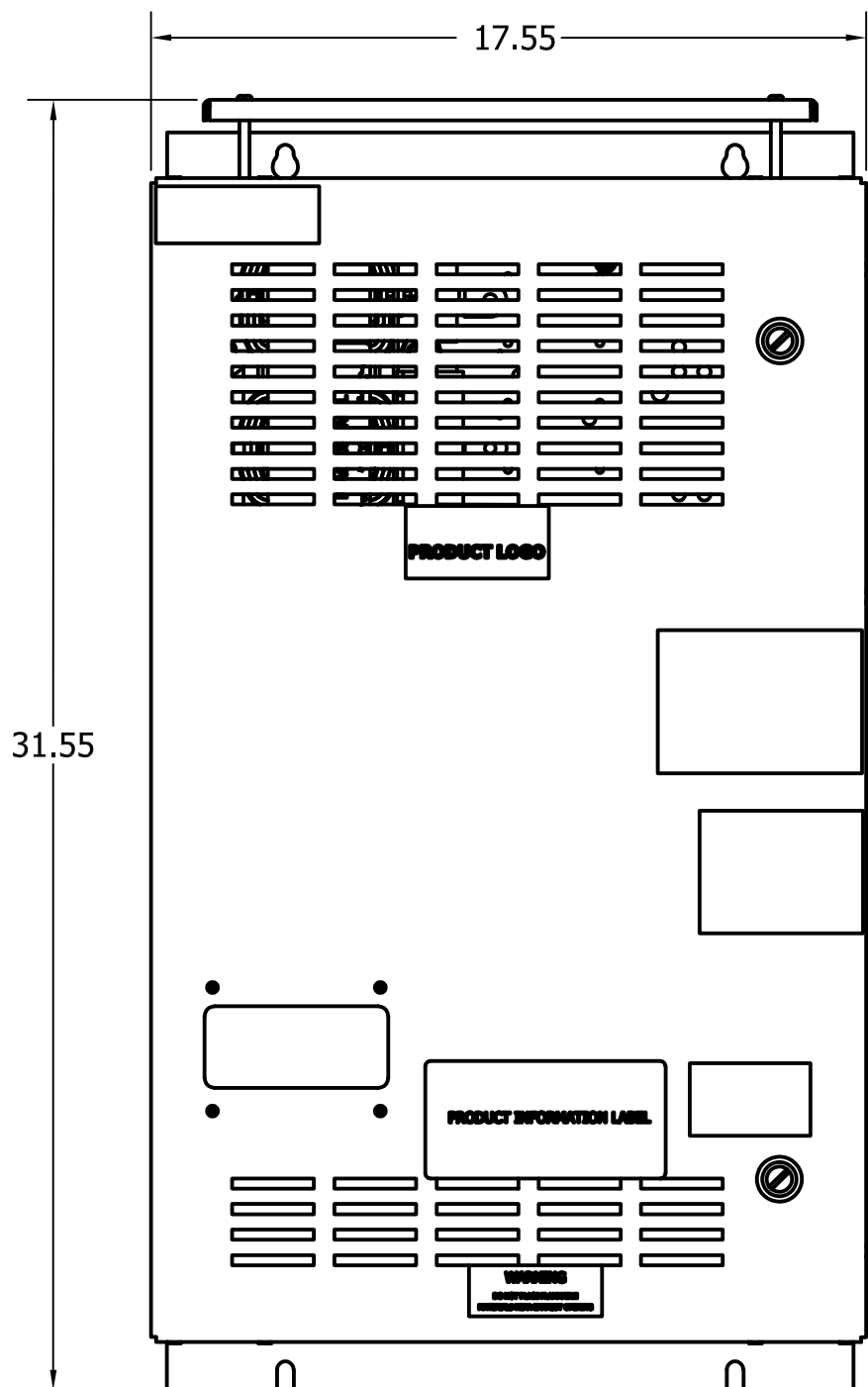
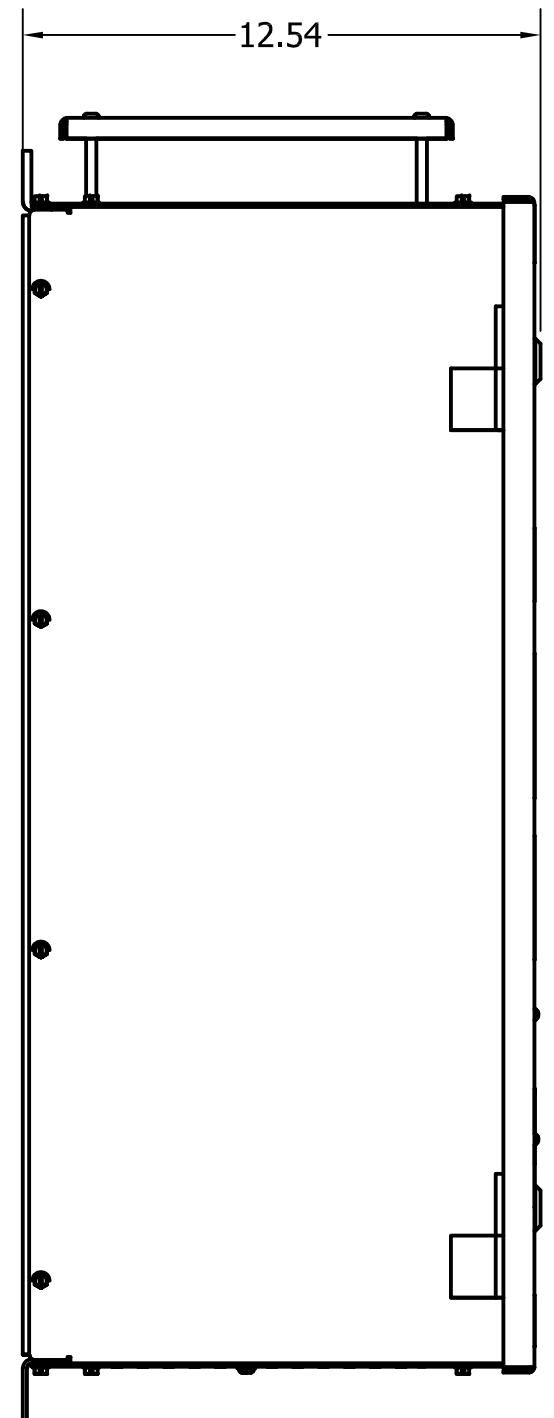
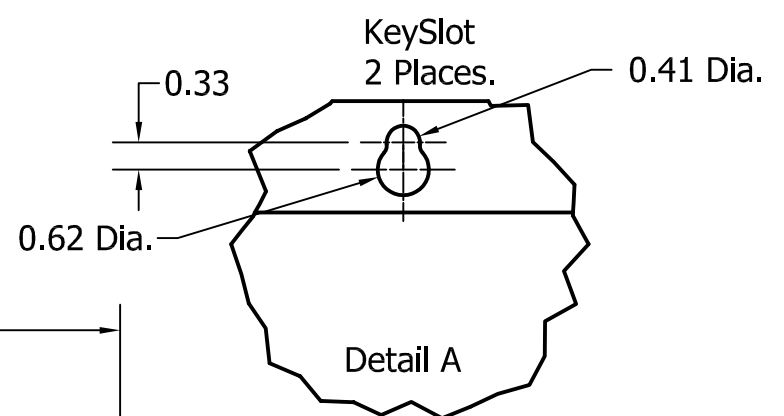
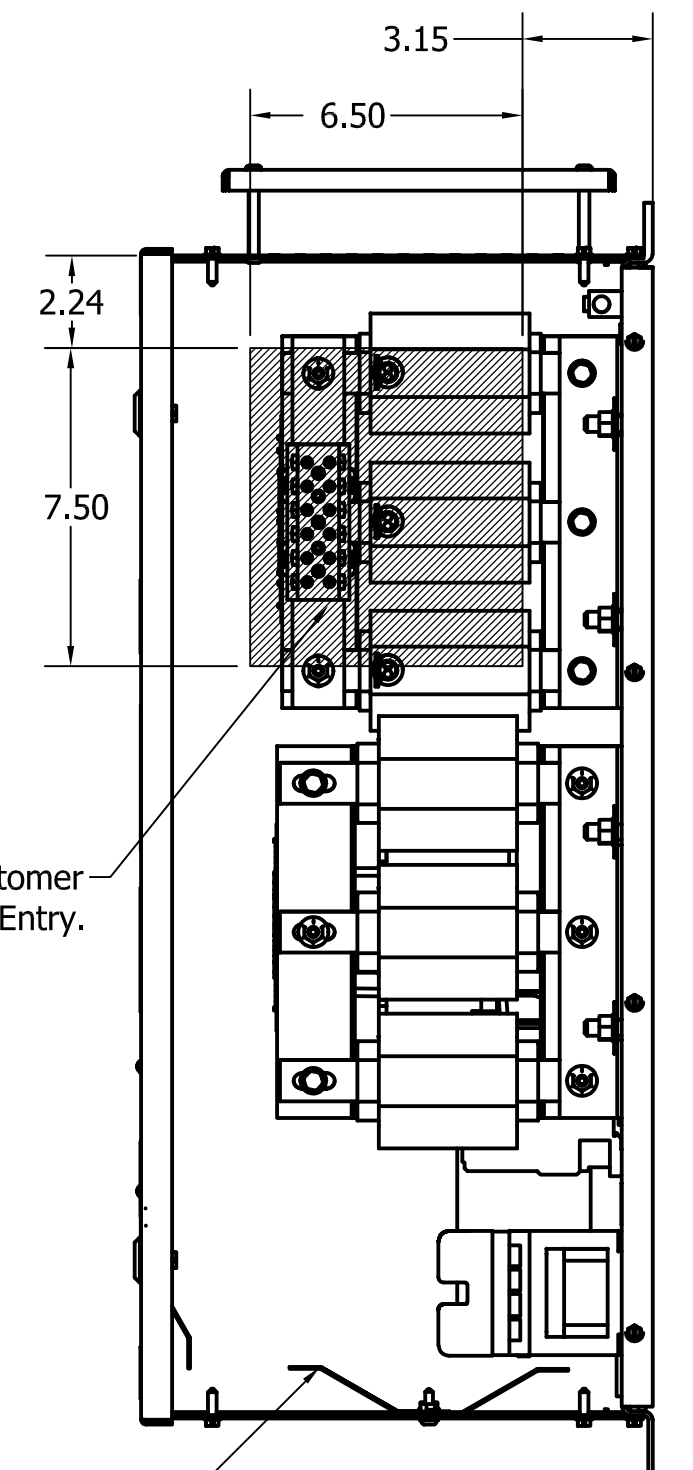
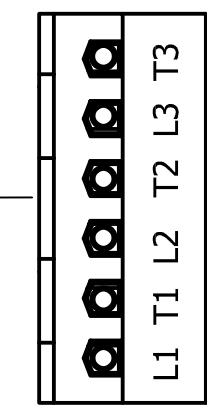

CUSTOMER IS RESPONSIBLE FOR INSTALLATION
TO MEET ALL NATIONAL AND LOCAL ELETRICAL CODES.

Material(s) Shall be RoHS Compliant

TCI, LLC CLAIMS PROPRIETARY RIGHTS IN THE MATERIAL HEREIN DISCLOSED. IT IS SUPPLIED WITHOUT PREDJUDICE TO ANY PATENT RIGHTS OF TCI AND MAY NOT BE REPRODUCED OR USED TO MANUFACTURE ANYTHING SHOWN THEREIN WITHOUT WRITTEN PERMISSION FROM TCI.

NO	REVISION	DATE	BY	SCALE
A	AS DESIGNED	10/3/17	DSW	ANGULAR +/- 1°
				FRACTIONAL +/- 1/16
				DECIMAL .XX +/- .25
				DECIMAL .XXX +/- .12

TCI W132 N10611 GRANT DRIVE
GERMANTOWN, WI 53022

HGL0060CW1C0000, 600V, 60HP, 3 Phase
HGL0060CW1S0000, 600V, 60HP, 3 Phase
60 Hz, Type 1, Low C, Passive Harmonic Filter

DRN. BY: DSW DATE: 10/3/17 DWG. No.: 107286DG
SCALE: 1/8 APRVD.

SHEET 1 OF 1