

HGL Open Part Number	Schematic Drawing #	Approx Weight (LBS)
HGL0060AW0S000#	30586-1	135
HGL0060AW0C000#	30586	140
HGL0060AW0C*00#	30586-PQ	143

Unit Specifications						
HP	kVar	Maximum Amps (A)	Harmonic	Volt	HZ.	Phase
60	10	77	5TH	480	60	3

HGL Enclosed Type1 Part Number	Schematic Drawing #	Approx Weight (LBS)
HGL0060AW1S000#	30586-1	200
HGL0060AW1C000#	30586	205
HGL0060AW1C*00#	30586-PQ	206

\* = Communications Option  
# = Mechanical Option

Note: For Torque Information See IOM Manual

Customer Connections.  
L1, T1, L2, T2, L3, T3  
Wire Range: 1 AWG to 22 AWG.

Ground Lug  
Wire Range: 1/0 to 14 AWG.

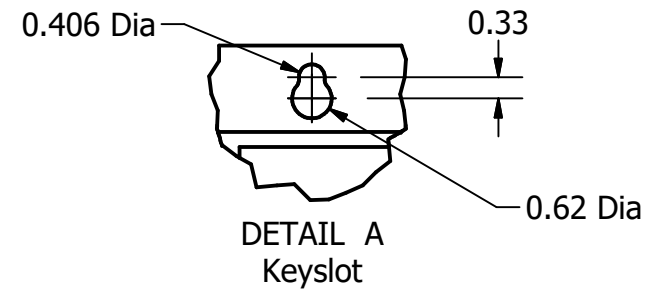

Thermal Switch, Terminal Block (Optional) Located on Inductors

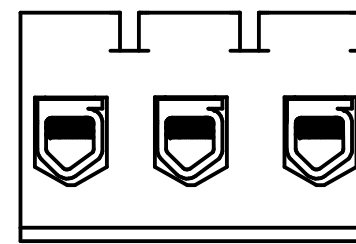

Wire Range: 18 AWG To 4 AWG.  
Torque: 20 LB-IN (2.3 Nm)

Switch Opens on Temperature Rise  
Contact Rating: 6A @ 120 VAC, Resistive  
Contact Rating: 5A @ 120 VAC, Inductive

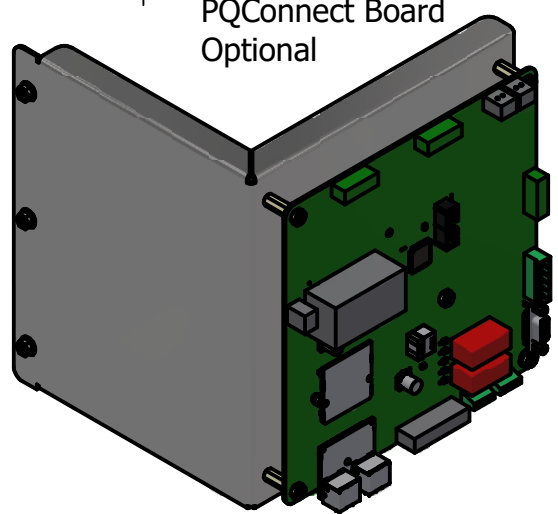
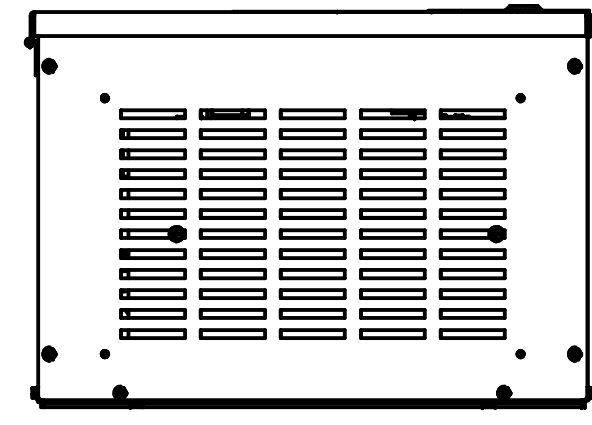
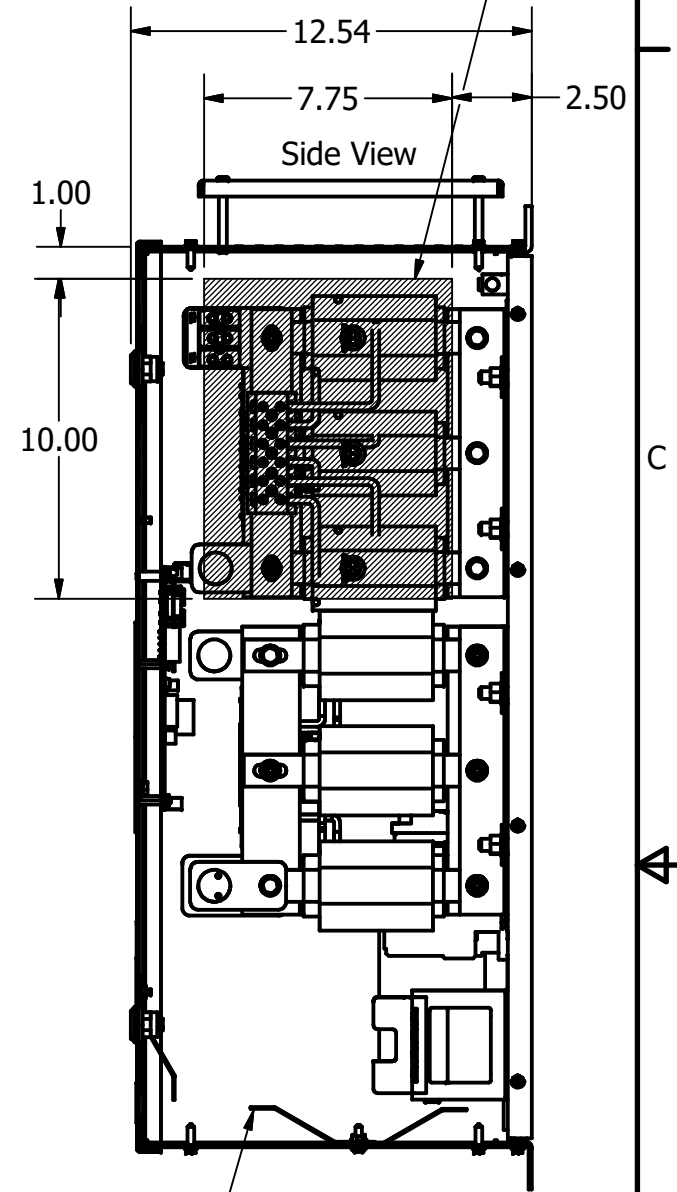
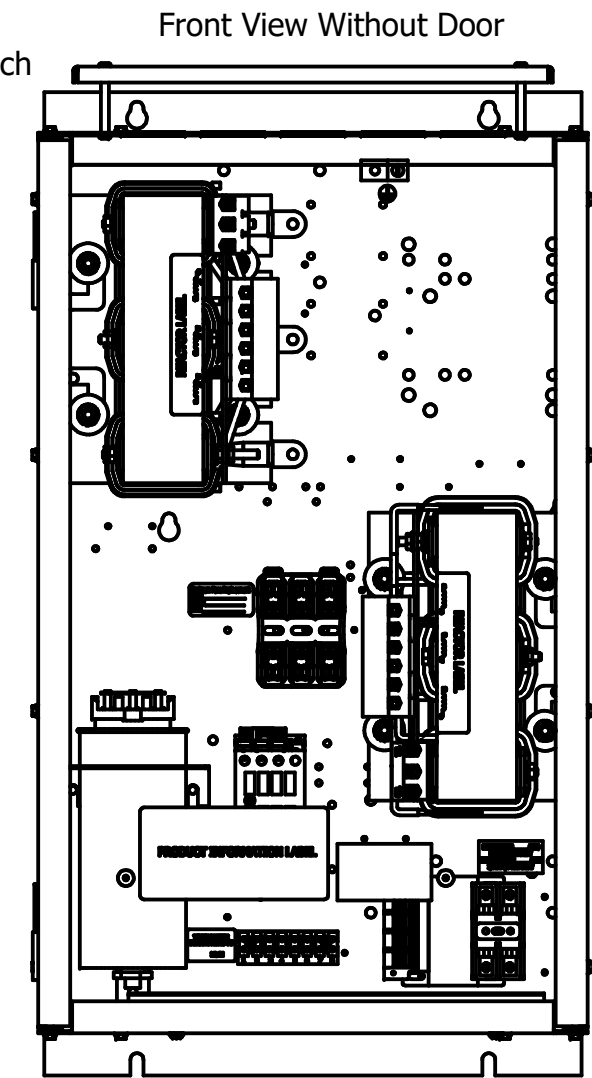
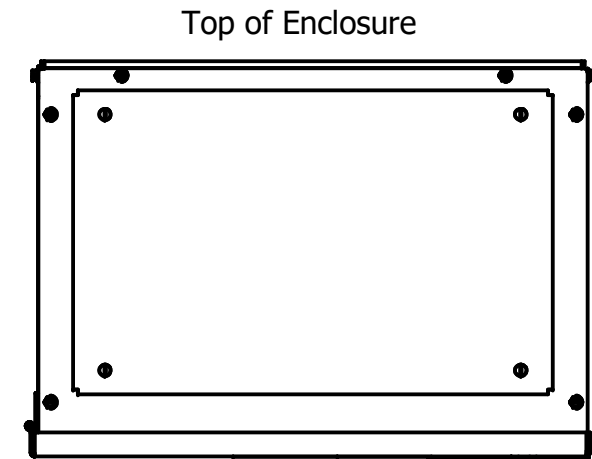
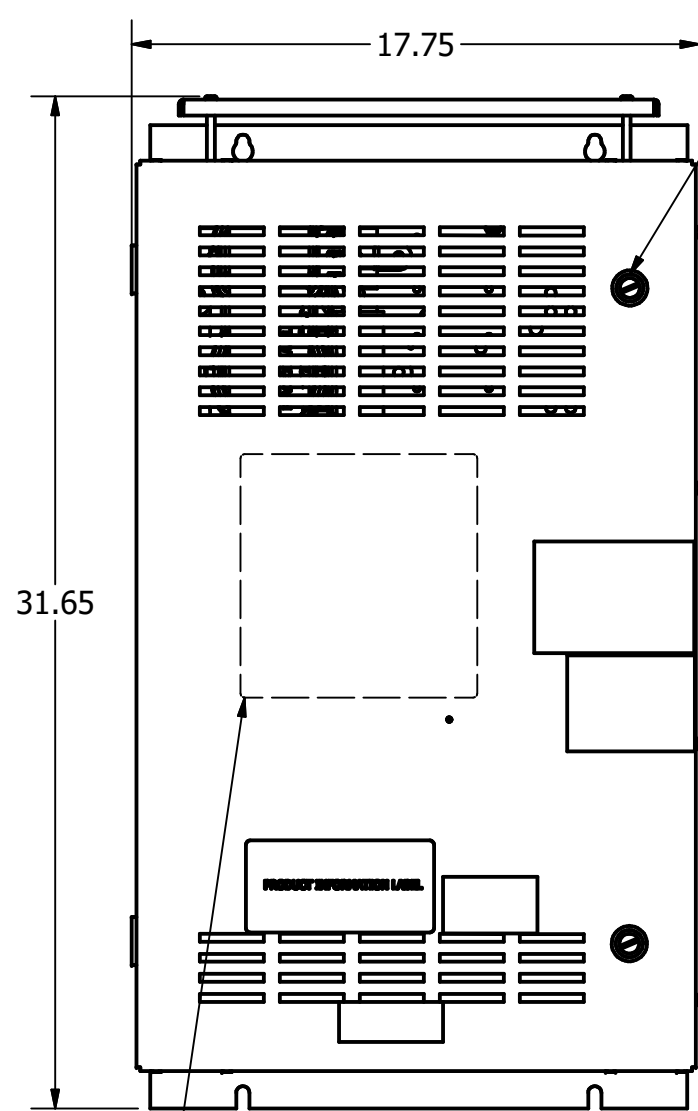
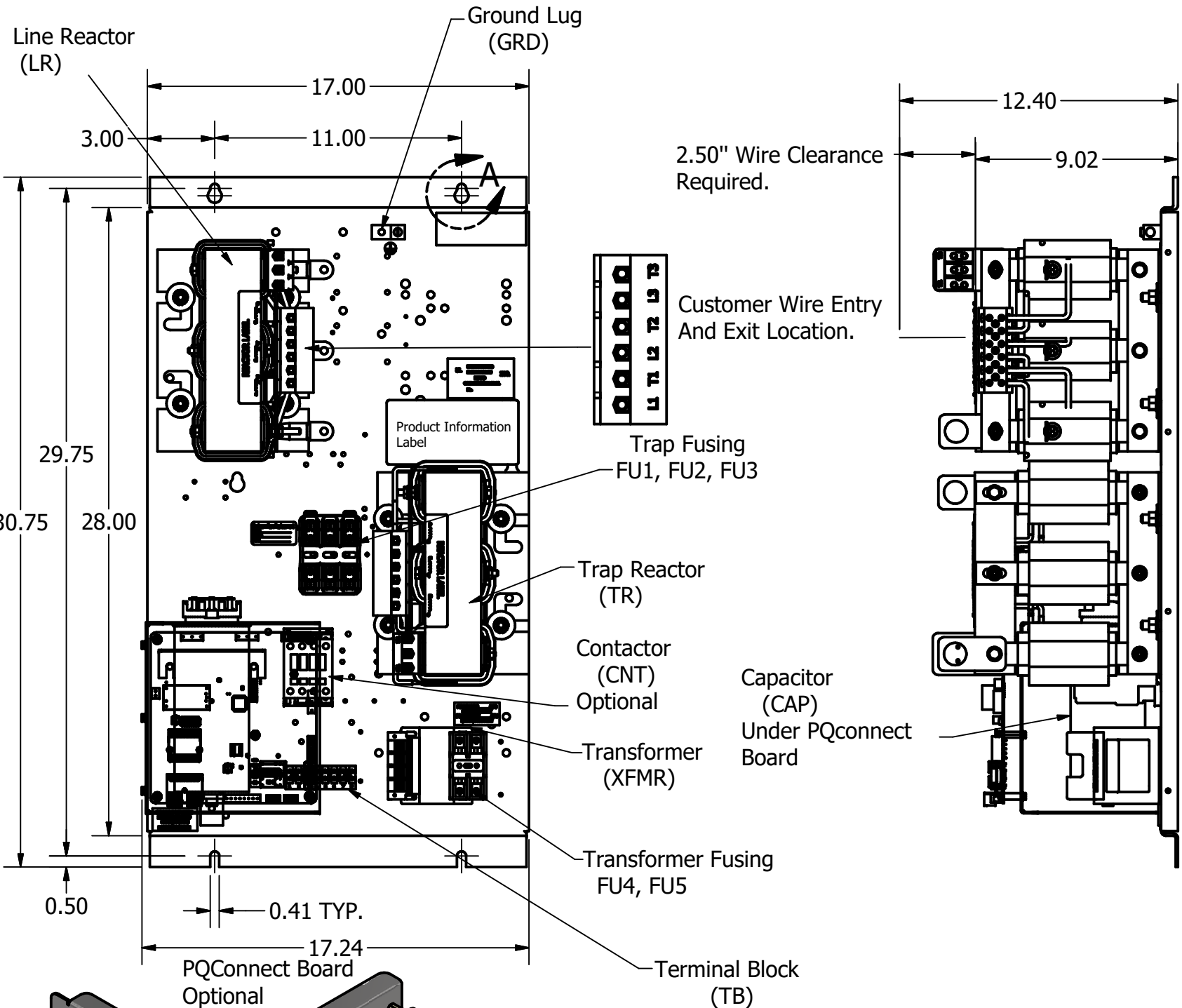

Terminal Block Location When Supplied

Note: Customer is responsible for proper cooling of filter components on open panels. Capacitors Maximum Ambient 50°C.

Components	HGL0060AW-----		
	0S000#/1S000#	0C000#/1C000#	0C*00#/1C*00#
Line Reactor (LR)	X	X	X
Trap Reactor (TR)	X	X	X
Capacitor (Cap)	X	X	X
Trap Fusing, FU1, FU2, FU3	X	X	X
Contactor (CNT)		X	X
Transformer (XFMR)	X	X	X
XFMR Fusing, FU4, FU5	X	X	X
PQConnect Board			X

Customer Is Responsible For Installation to Meet All National And Local Electrical Codes.

Material(s) Shall be RoHS Compliant

THE INFORMATION AND DESIGNS CONTAINED IN THIS DRAWING ARE CONFIDENTIAL AND THE PROPRIETARY PROPERTY OF ALLIED MOTION TECHNOLOGIES INC. AND ITS SUBSIDIARIES. NEITHER THIS DESIGN NOR ANY INFORMATION CONTAINED IN THIS DRAWING MAY BE REPRODUCED OR DISCLOSED TO OTHERS WITHOUT THE EXPRESS WRITTEN CONSENT OF ALLIED MOTION TECHNOLOGIES INC. AND ITS SUBSIDIARIES.

NO	REVISION	DATE	BY	ANGULAR
E	6728 Mechanical Options Added	07/12/24	JRN	± 1°
D	6024, Add PQ Option	8/26/2022	GJS	
C	5653, GE to ABB CNT CHG.	8/31/2021	DSW	
B	PQConnect Board Added.	2/27/19	DSW	

**TCL** W132N10611 Grant Drive  
Germantown, WI 53022  
© 2022 TCL, LLC

An Allied Motion Company

HarmonicGuard Low Cap, HGL0060AW-----  
60HP, 480/3/60, Open and Type 1.

DRN BY: DSW DATE: 3/30/17 SIZE: C  
SCALE: 1/8 APRVD: 107016DG SHT 1 OF 1