

Unit Specifications					
kVar	Harmonic	Volt	HZ.	Phase	HP
6	5TH	600	60	3	40
TCI Part Number		Option	Weight	Schematic	
HGL0040CW1S0000		Standard	181lbs	30807-40S	
HGL0040CW1C0000		Contactant	185lbs	30807-40C	

See IOM Manual For Wire Range  
And Tightening Torque.

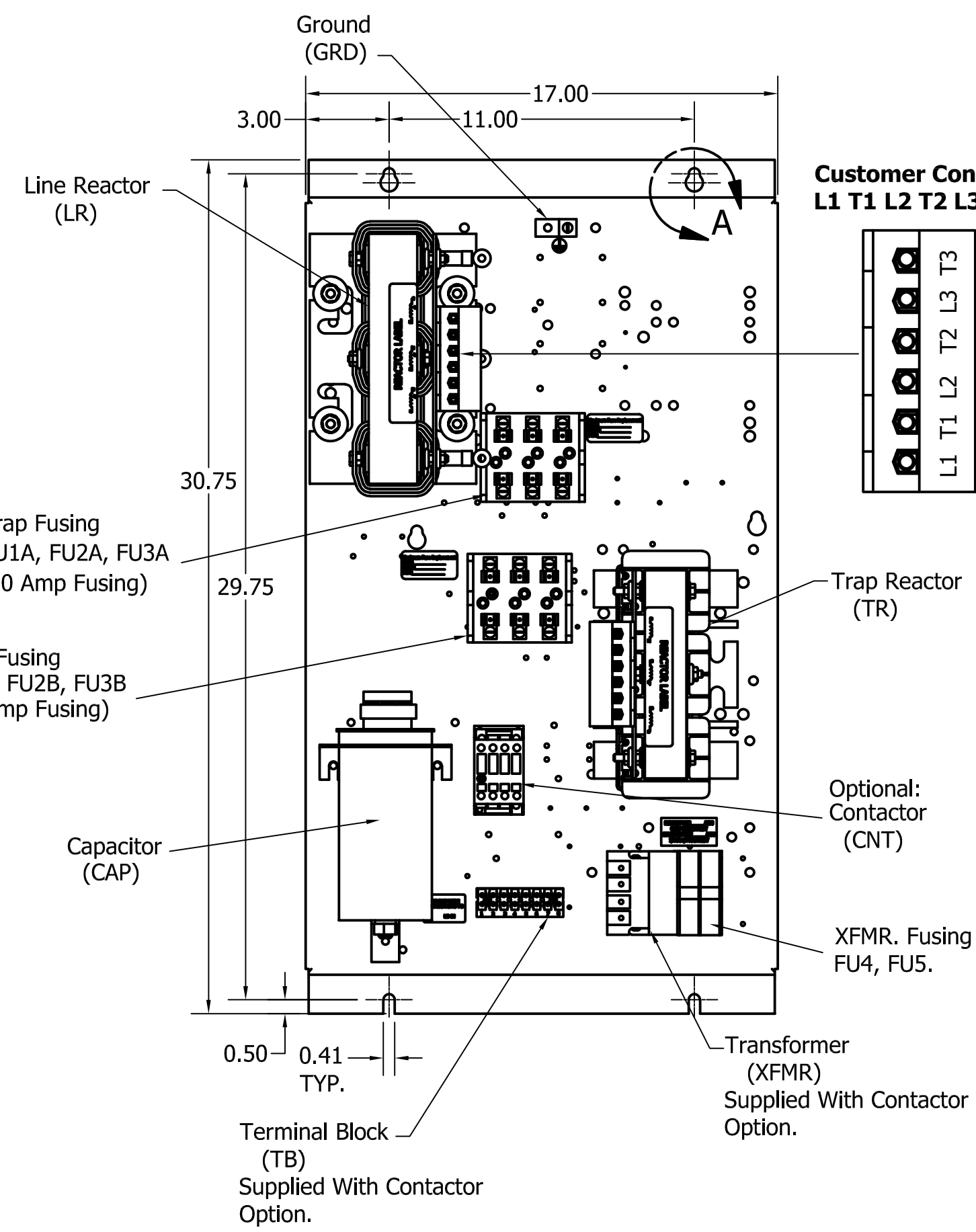

Customer Connection  
L1 T1 L2 T2 L3 T3

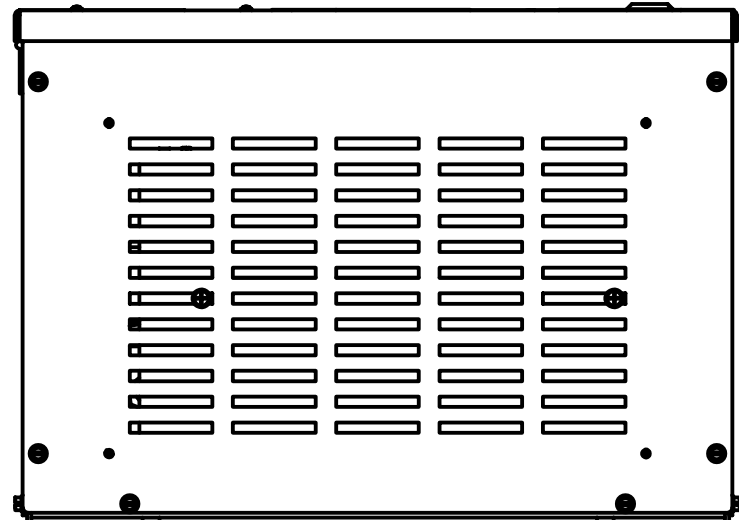
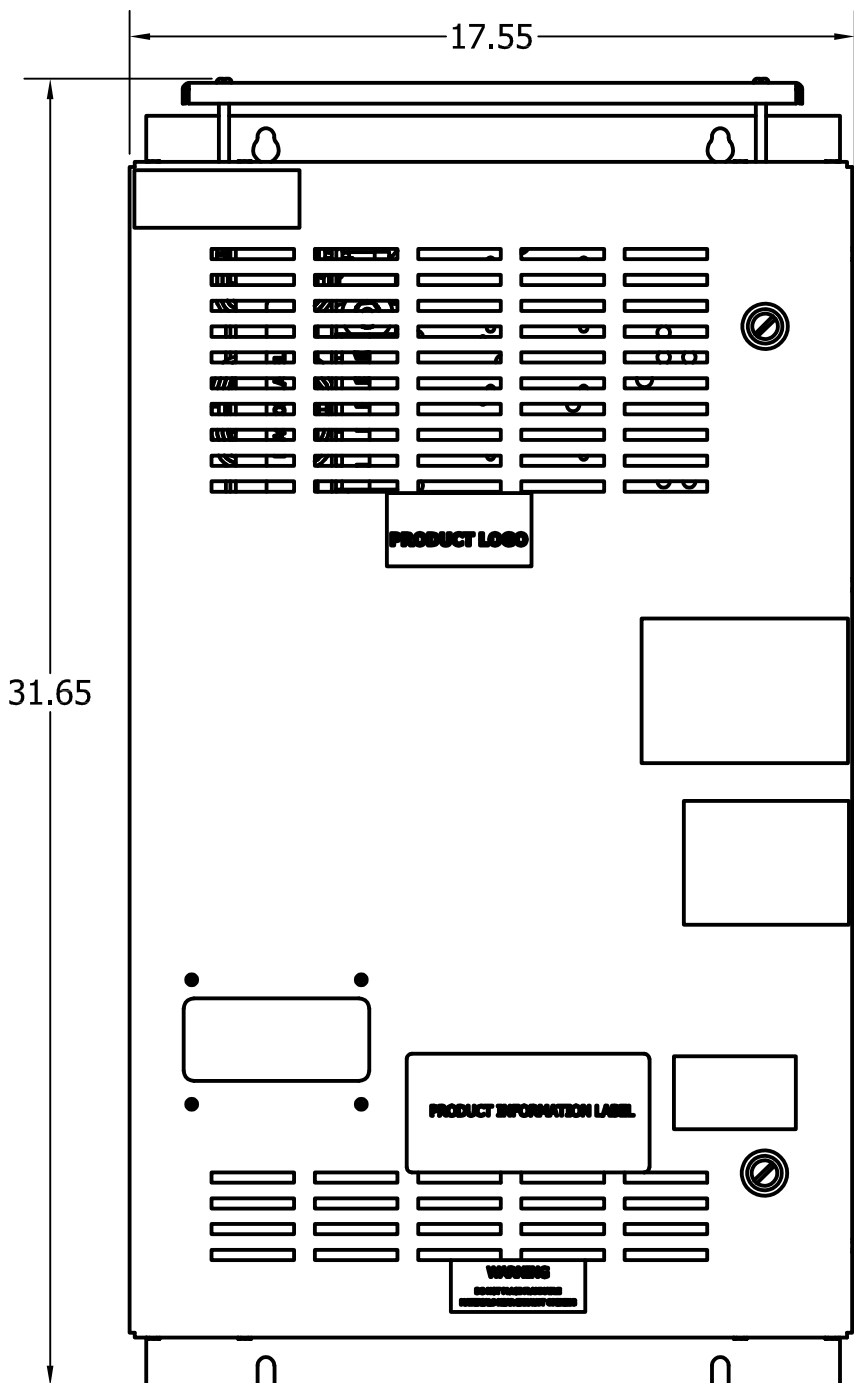
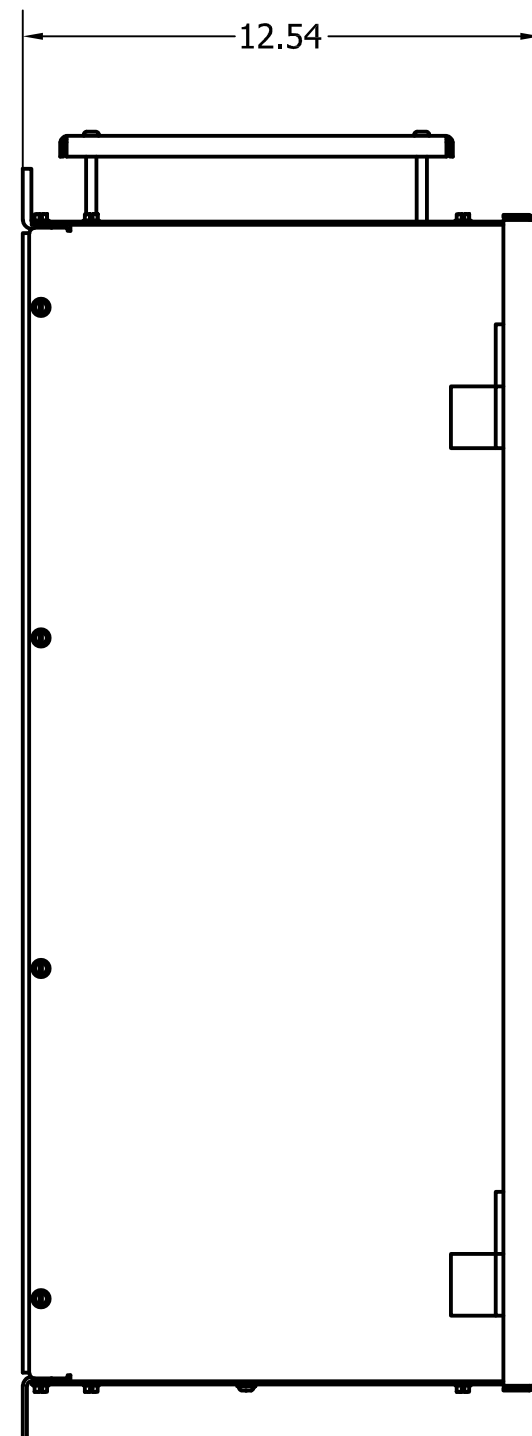
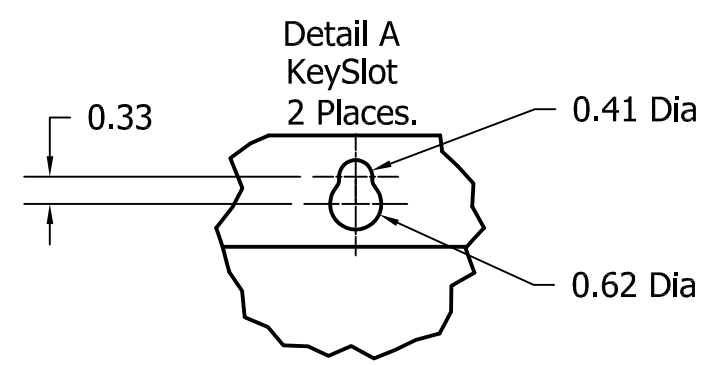
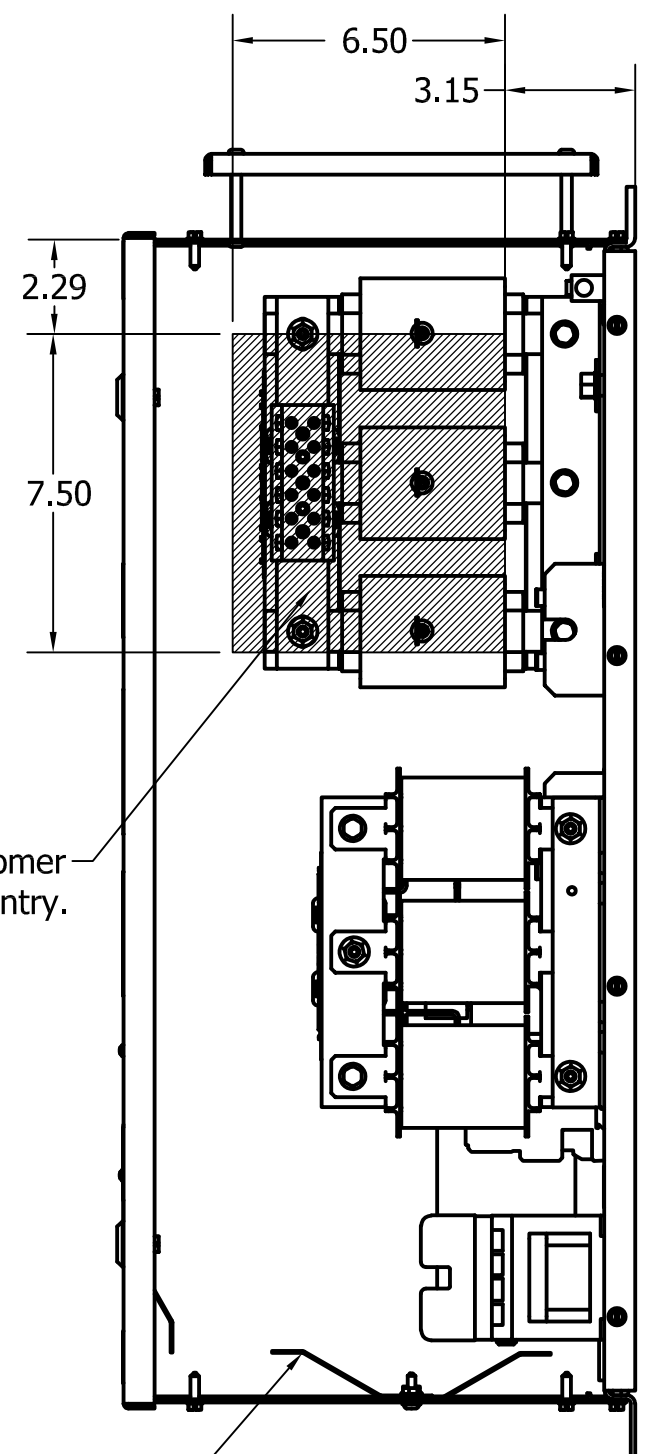

Suggested Customer  
Enclosure Entry.

Note: UL Shields Not Needed  
On Standard Version

CUSTOMER IS RESPONSIBLE FOR INSTALLATION  
TO MEET ALL NATIONAL AND LOCAL ELETRICAL CODES.

Material(s) Shall be RoHS Compliant

TCI, LLC CLAIMS PROPRIETARY RIGHTS IN THE MATERIAL HEREIN DISCLOSED. IT IS SUPPLIED WITHOUT PREDJUDICE TO ANY PATENT RIGHTS OF TCI AND MAY NOT BE REPRODUCED OR USED TO MANUFACTURE ANYTHING SHOWN THEREIN WITHOUT WRITTEN PERMISSION FROM TCI.

NO	REVISION	DATE	BY	SCALE
A	AS DESIGNED	10/3/17	DSW	ANGULAR +/- 1°

		W132 N10611 GRANT DRIVE GERMANTOWN, WI 53022
HGL0040CW1C0000, 600V, 40HP, 3 Phase HGL0040VW1S0000, 600V, 40HP, 3 Phase 60 Hz, Type 1, Low C, Passive Harmonic Filter		
DRN. BY DSW	DATE 10/3/17	DWG. No. 107284DG
SCALE 1/8	APRVD.	SHEET 1 OF 1