

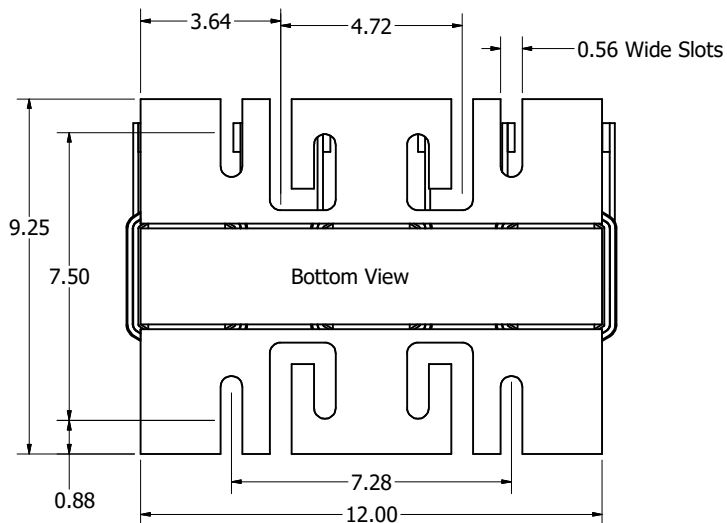

Part Number	Horsepower (HP)	Amps (A)	--uH +/-10%	Weight (LBS)	Terminal Hole Size (Inches)	Available Lug Kit
KLR160CCB	125	160	230	85	0.28	SLK11

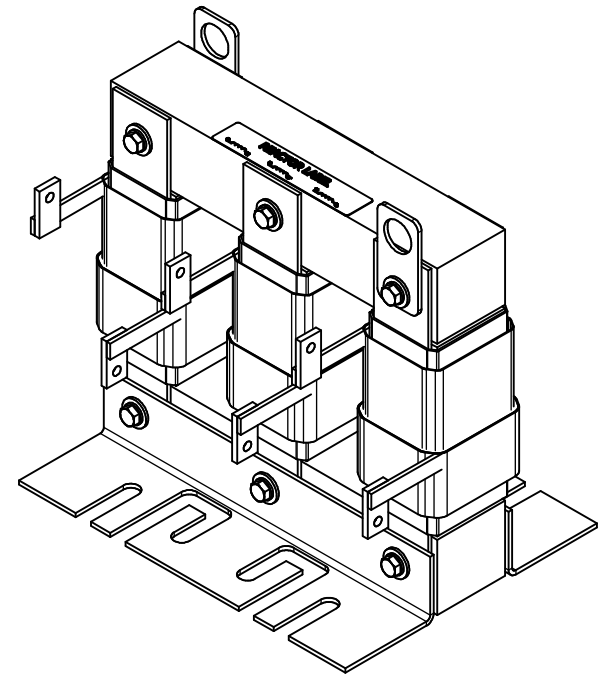
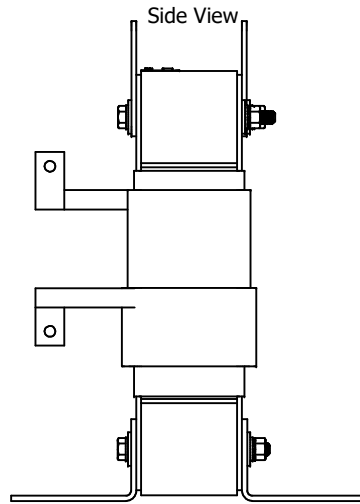
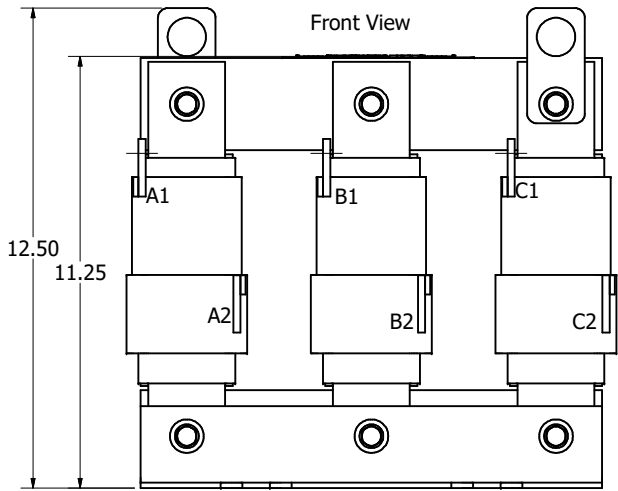
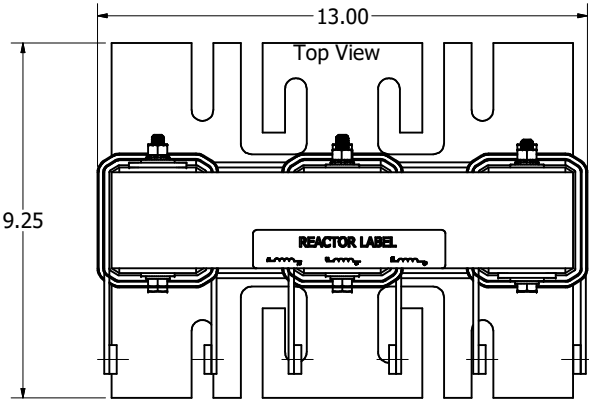

Customer Is Responsible For Installation
To Meet All National And Local Electrical Codes.

Material(s) Shall be RoHS Compliant

THE INFORMATION AND DESIGNS CONTAINED IN THIS DRAWING ARE CONFIDENTIAL AND THE PROPRIETARY PROPERTY OF ALLIED MOTION TECHNOLOGIES INC. AND ITS SUBSIDIARIES. NEITHER THIS DESIGN NOR ANY INFORMATION CONTAINED IN THIS DRAWING MAY BE REPRODUCED OR DISCLOSED TO OTHERS WITHOUT THE EXPRESS WRITTEN CONSENT OF ALLIED MOTION TECHNOLOGIES INC. AND ITS SUBSIDIARIES.				TOLERANCES (EXCEPT AS NOTED)		 W132N10611 (Rev 11/24) Germantown, WI 53022 © 2024 TCI, LLC	
				DECIMAL			.XX ± .25 .XXX ± .10
				FRACTIONAL			± 1/32
				ANGULAR			± 1°
REV	DATE	BY	SCALE	DWG. BY	DATE	REV	SIZE
NO	REVISION	DATE	BY	SCALE	DWG. BY	DATE	REV
				1:2.5	DSW	9/11/2024	109647DG
				1:2.5	DSW	9/11/2024	109647DG