

| 480 Rated Voltage, 600 Max Voltage, Output |                 |                  |             |              |                             |                   |
|--|-----------------|------------------|-------------|--------------|-----------------------------|-------------------|
| Part Number                                | Horsepower (HP) | Maximum Amps (A) | ---uH+/-10% | Weight (LBS) | Terminal Hole Size (Inches) | Available Lug Kit |
| KLR250ACB                                  | 200             | 250              | 88          | 91           | 0.44                        | SLK12             |

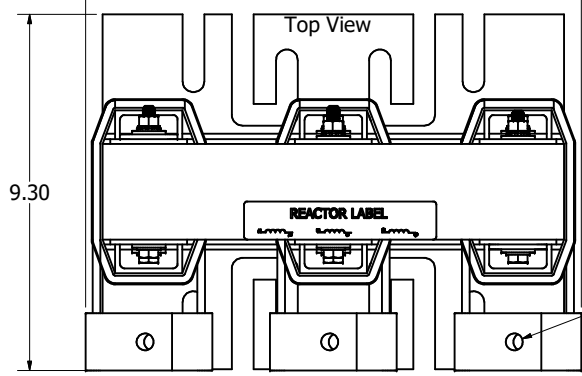

Ø0.44

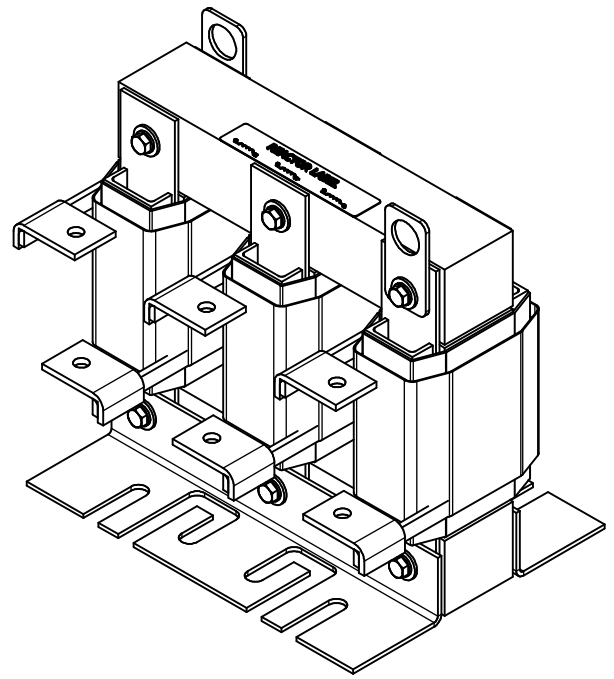
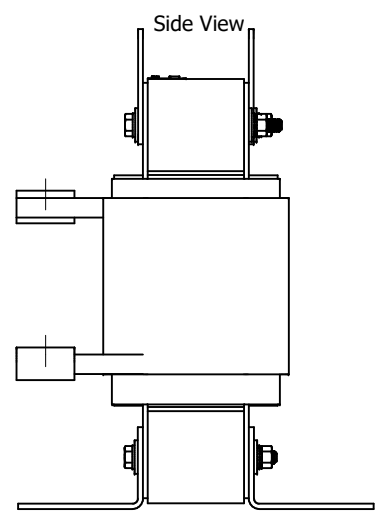
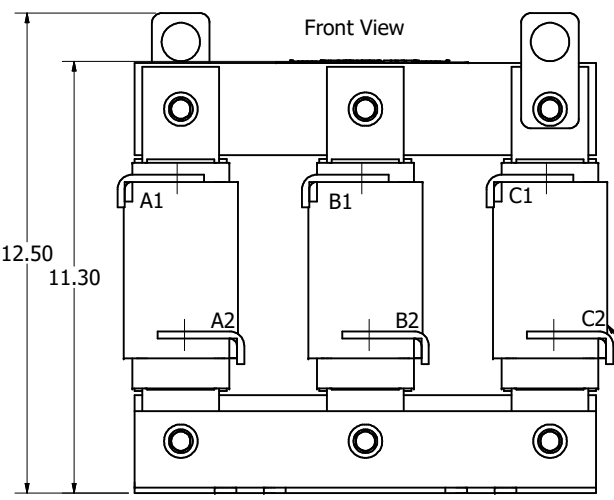

Marking for Reference Only.

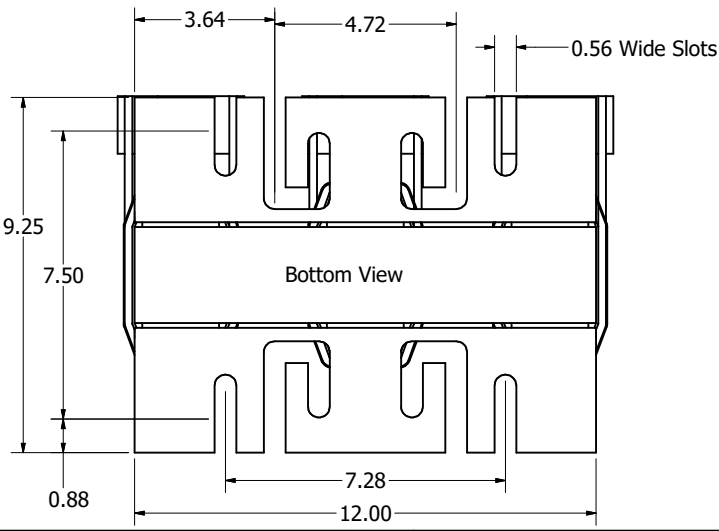

Customer Is Responsible For Installation To Meet All National And Local Electrical Codes.  
Material(s) Shall be RoHS Compliant

|  |    |                                   |          |     |                              |  |  |
|--|----|-----------------------------------|----------|-----|------------------------------|--|--|
| THE INFORMATION AND DESIGNS CONTAINED IN THIS DRAWING ARE CONFIDENTIAL AND THE PROPRIETARY PROPERTY OF ALLIED MOTION TECHNOLOGIES INC. AND ITS SUBSIDIARIES. NEITHER THIS DESIGN NOR ANY INFORMATION CONTAINED IN THIS DRAWING MAY BE REPRODUCED OR DISCLOSED TO OTHERS WITHOUT THE EXPRESS WRITTEN CONSENT OF ALLIED MOTION TECHNOLOGIES INC. AND ITS SUBSIDIARIES. | NO | REVISION                          | DATE     | BY  | TOLERANCES (EXCEPT AS NOTED) | <br><small>W132N10611 (Rev 11/20) Germantown, WI 53022</small><br><small>© 2024 TCI, LLC</small><br><b>KLR250ACB</b><br>(L Frame) | <small>DRN BY: DSW</small><br><small>DATE: 9/4/2024</small><br><small>SCALE: 1:2.5</small><br><small>REVISED</small><br><small>FILE</small><br><small>SHT 1 OF 1</small> |
|  | F  | 6787 was KLR30-2, (Matching Revs) | 9/4/2024 | DSW | DECIMAL                      |  |  |
|  |    |                                   |          |     | FRACTIONAL                   |  |  |
|  |    |                                   |          |     | ANGULAR                      |  |  |