

Top View

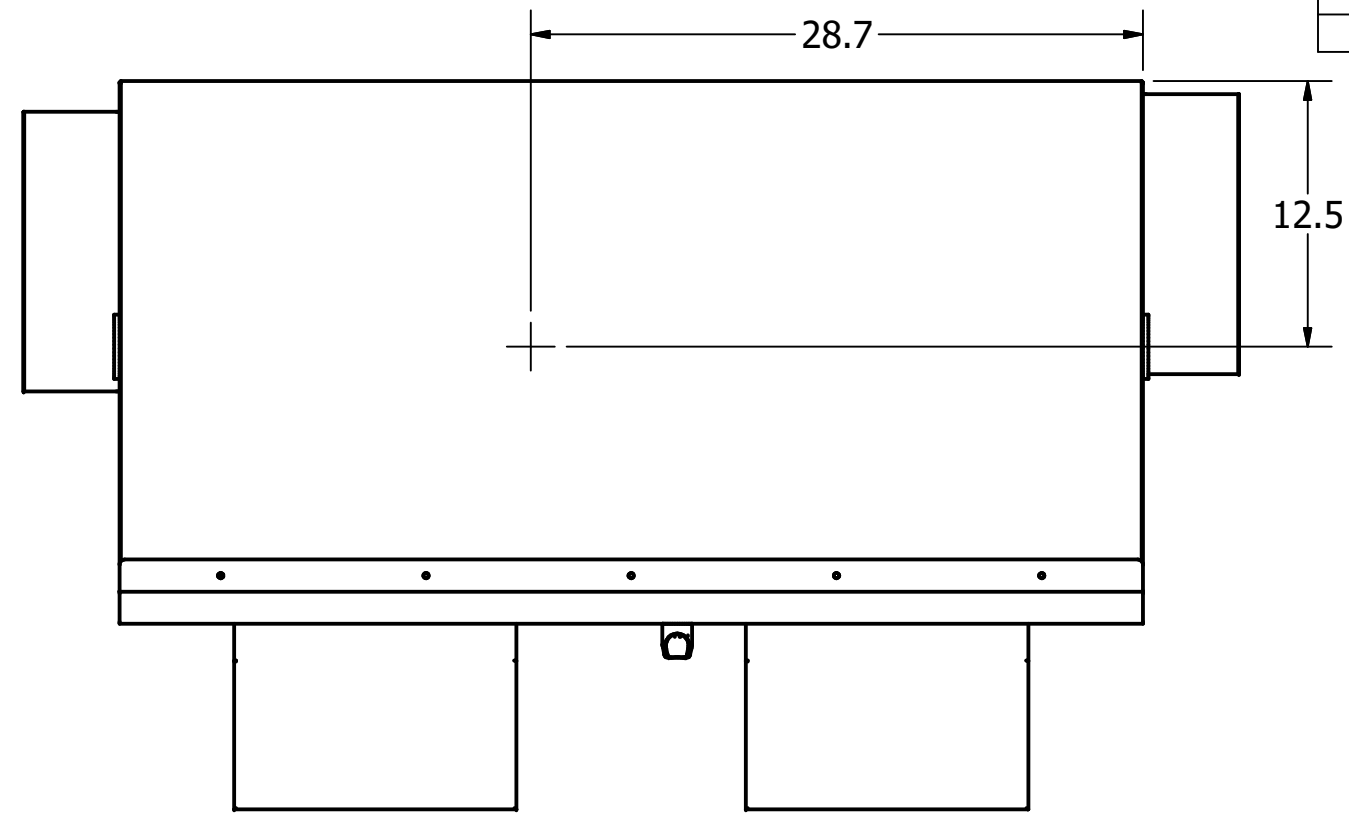

UNIT SPECIFICATIONS							
Part Number	HP	KVAR	HARMONIC	VOLT	Hz	PHASE	AMPS
109395-01	550	68	5TH	480	60	3	655

SCHEMATIC : 30586-PQ6

Notes:

1. Customer is responsible for installation to meet all national and local electrical codes.
2. Use only hubs or fittings that comply with UL514B for type 3R enclosures.
3. Approx. WT LBS : 950
4. Enclosure Color: ANSI-61 Gray
5. PQconnect Programming Model: Custom Unit HGL0550AWxC1xxxELC

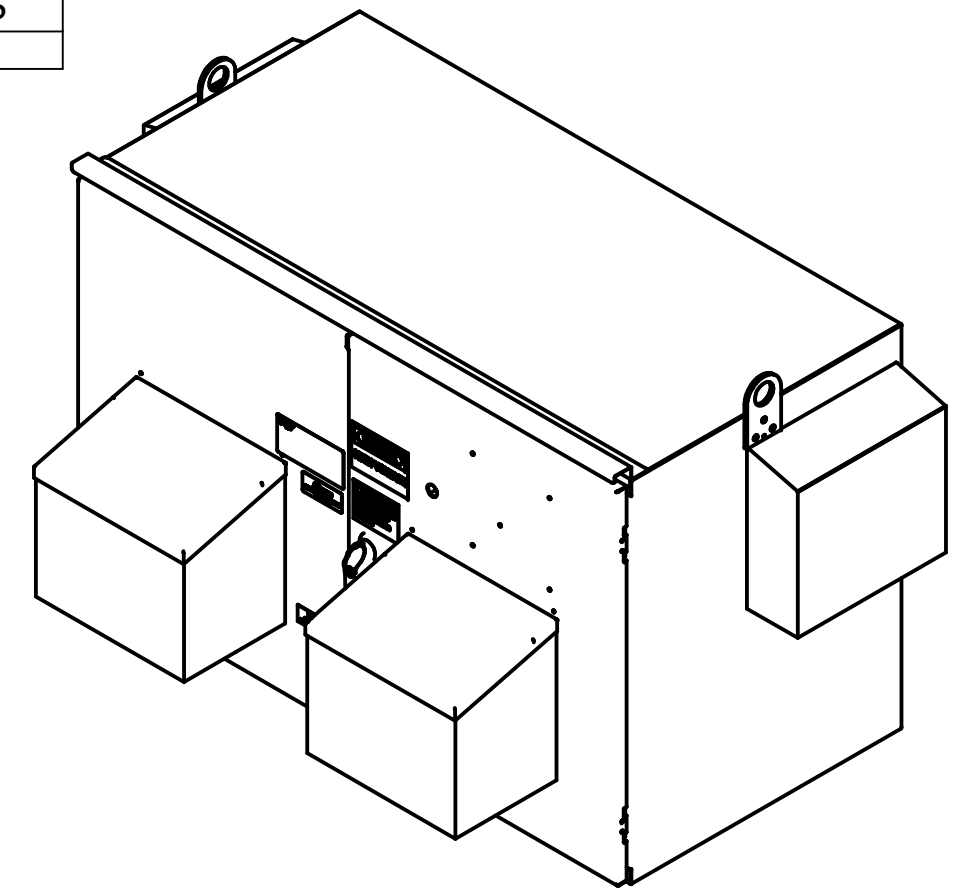

Front View Without Doors

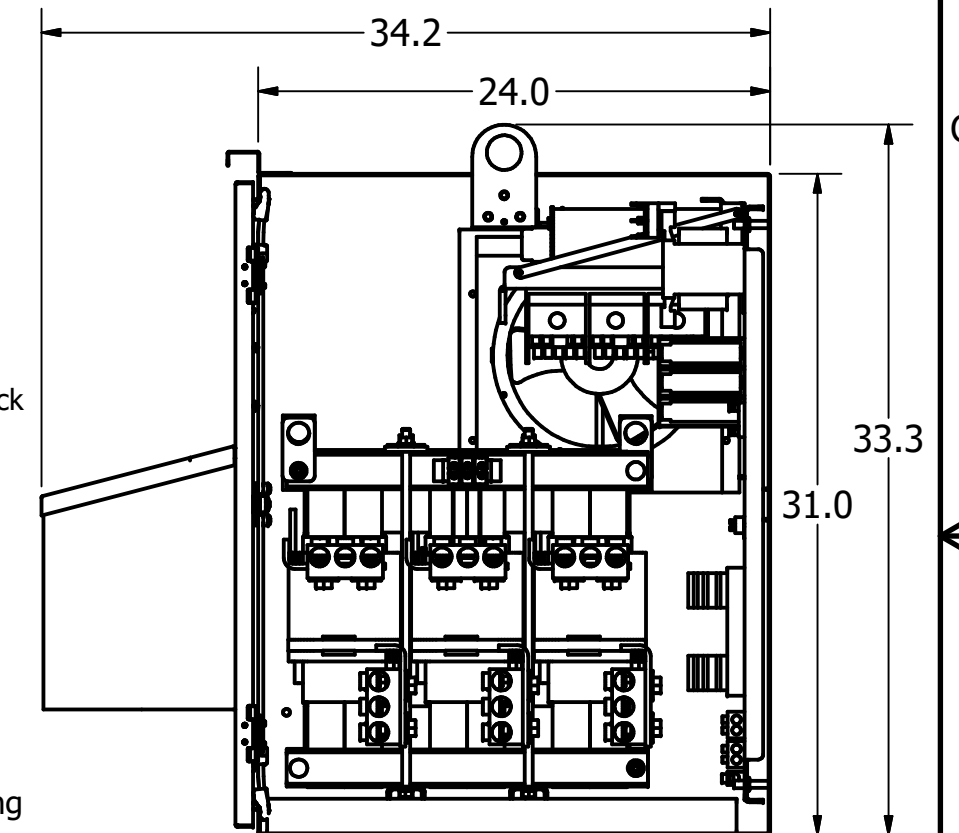
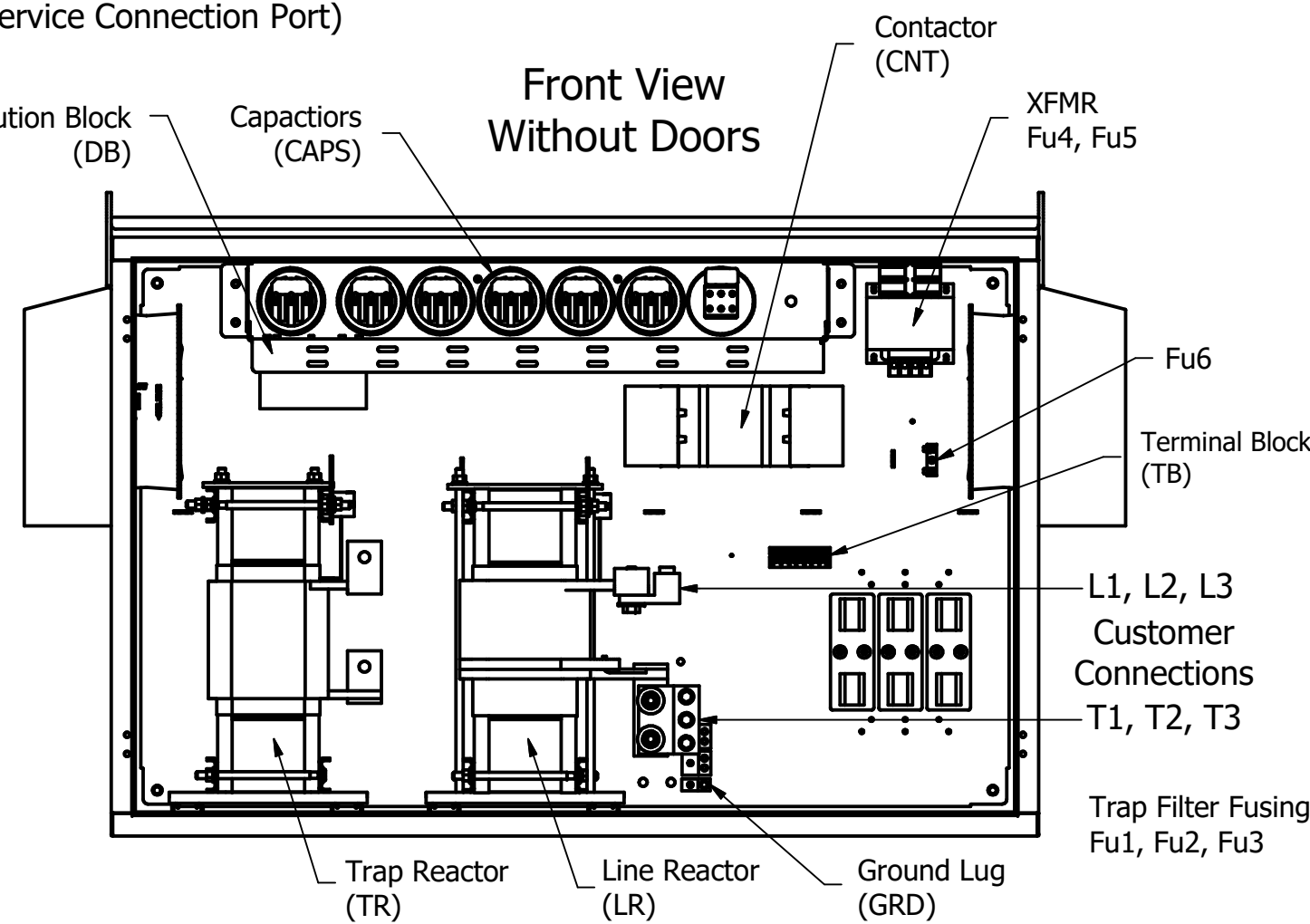

Side View Without Wall

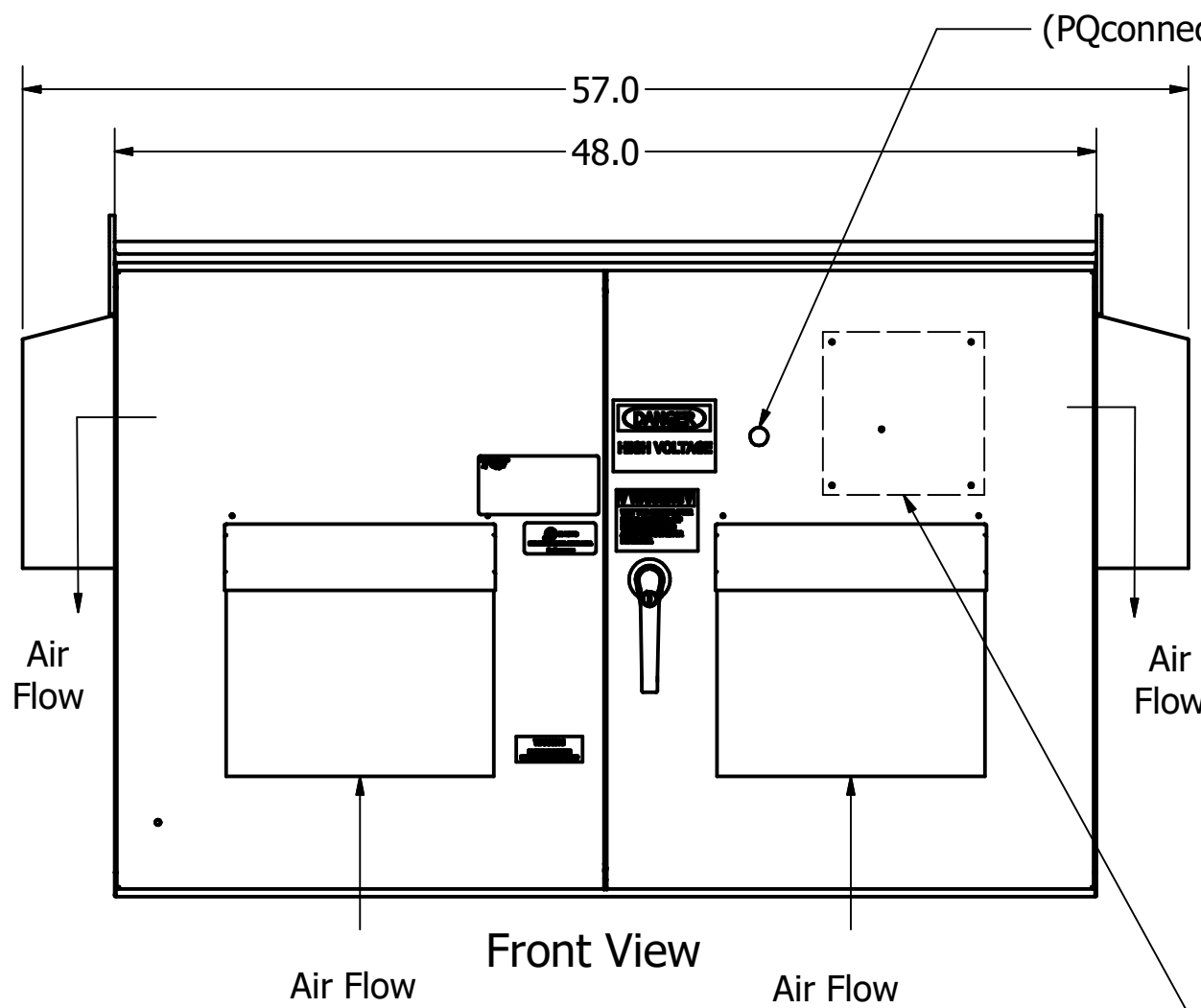

Front View

(PQconnect Board Service Connection Port)

PQconnect Contactor Control Board Mounted To Inside Of Door

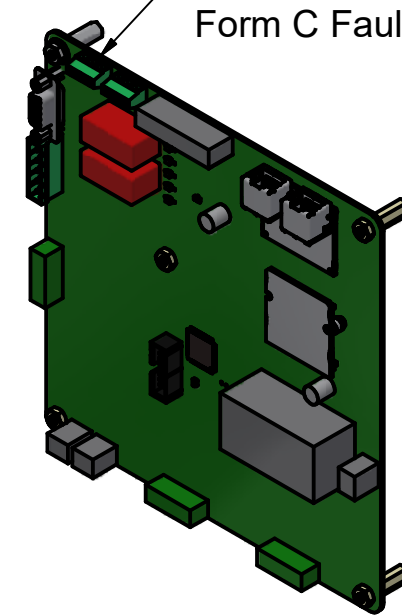

Thermal Switches Installed In Line Reactor And Tuning Reactor Wired To PQconnect For Monitoring

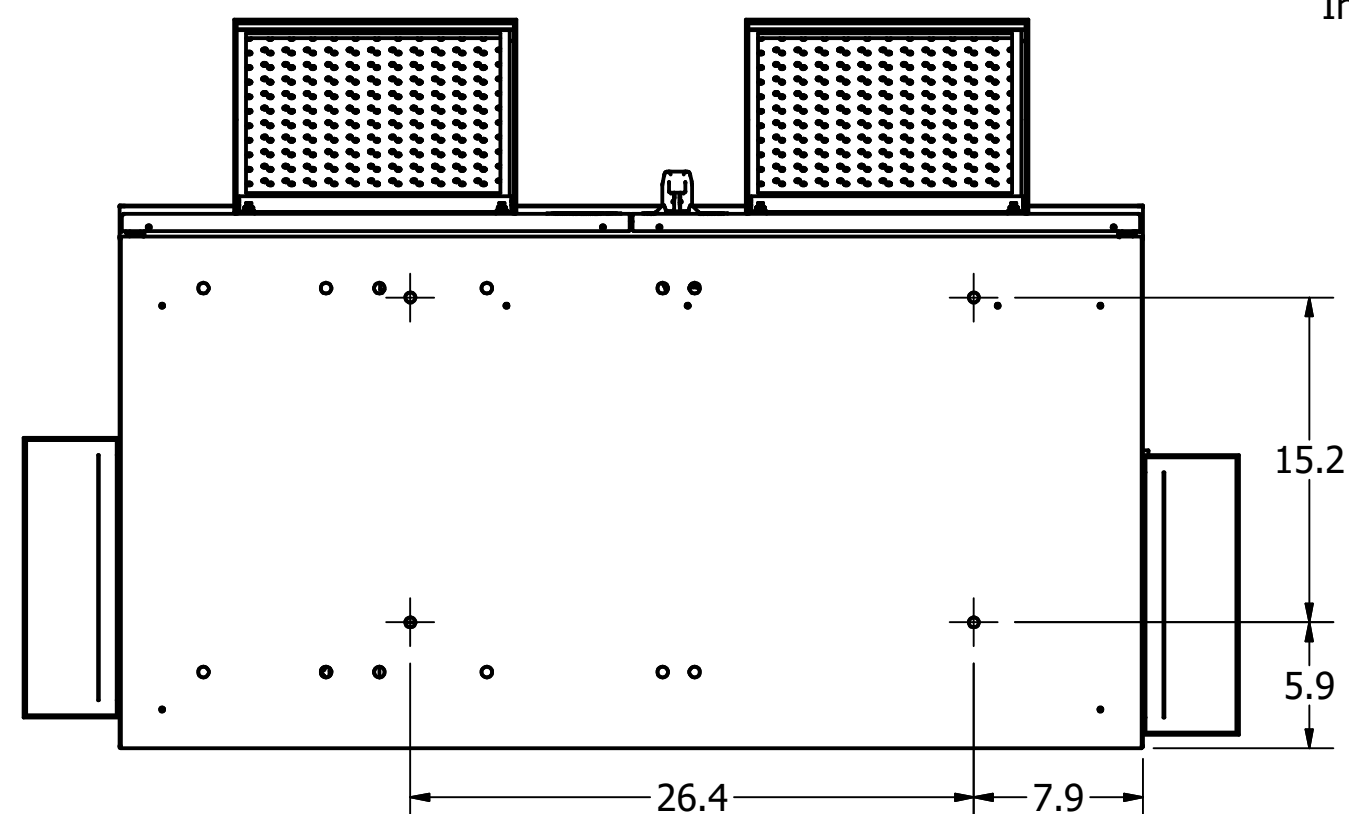

Bottom View

GROUND LUG:
WIRE RANGE - FIVE 2/0-14AWG
TIGHTENING TORQUE 50 LB-IN.

L1	L2	L3	T1	T2	T3
----	----	----	----	----	----

CUSTOMER CONNECTIONS:
WIRE RANGE - THREE 600MCM-4
TIGHTENING TORQUE 500 LB-IN.

THE INFORMATION AND DESIGNS CONTAINED IN THIS DRAWING ARE CONFIDENTIAL AND THE PROPRIETARY PROPERTY OF ALLIED MOTION TECHNOLOGIES INC. AND ITS SUBSIDIARIES. NEITHER THIS DESIGN NOR ANY INFORMATION CONTAINED IN THIS DRAWING MAY BE REPRODUCED OR DISCLOSED TO OTHERS WITHOUT THE EXPRESS WRITTEN CONSENT OF ALLIED MOTION TECHNOLOGIES INC. AND ITS SUBSIDIARIES.

NO	REVISION	DATE	BY
A	As Designed	10/24/23	JRN

TOLERANCES (EXCEPT AS NOTED)	
DECIMAL	.XX ± .03 .XXX ± .010
FRACTIONAL	± 1/32
ANGULAR	± 1°

TCL W132N10611 Grant Drive
Germantown, WI 53022
© 2023 TCL, LLC

An Allied Motion Company

Multistack, HGL, 550HP, 480/3/60, Type 3R
CNT, PQconnect, Low Profile, 2 Tsw, Spcl Low C

DRN BY: JRN DATE: 10/24/23 109395-01DG
SCALE: 1/9 APRVD: SIZE: C SHT 1 OF 1