

TCI Part Number	Rated Amps (A)	Rated Voltage (V)	Hz	---uH ±5%	Approx Weight (LBS)	Attached Lug Kit
KLRUL750CPTMG	750	600	60	80	610	SLK16

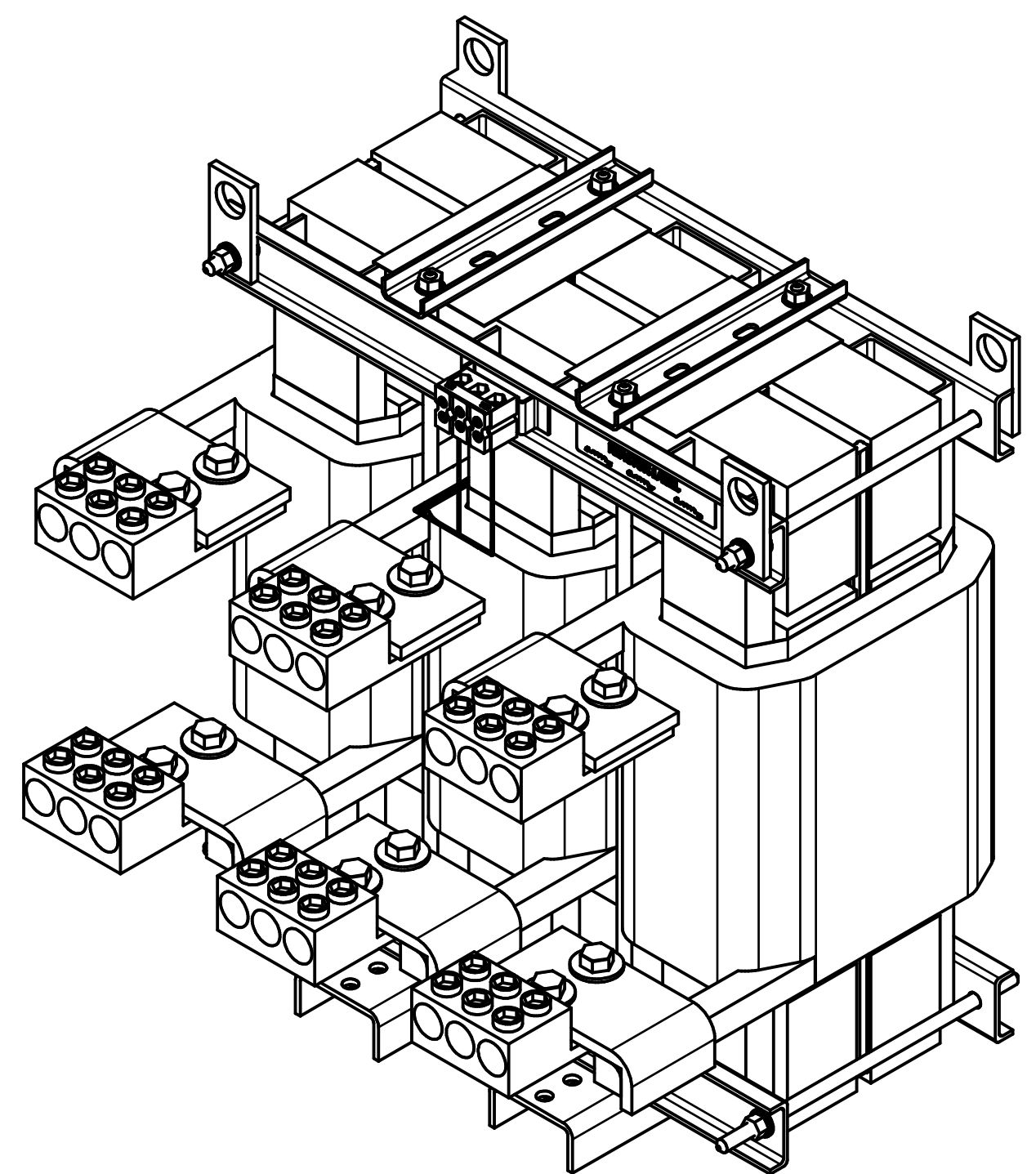
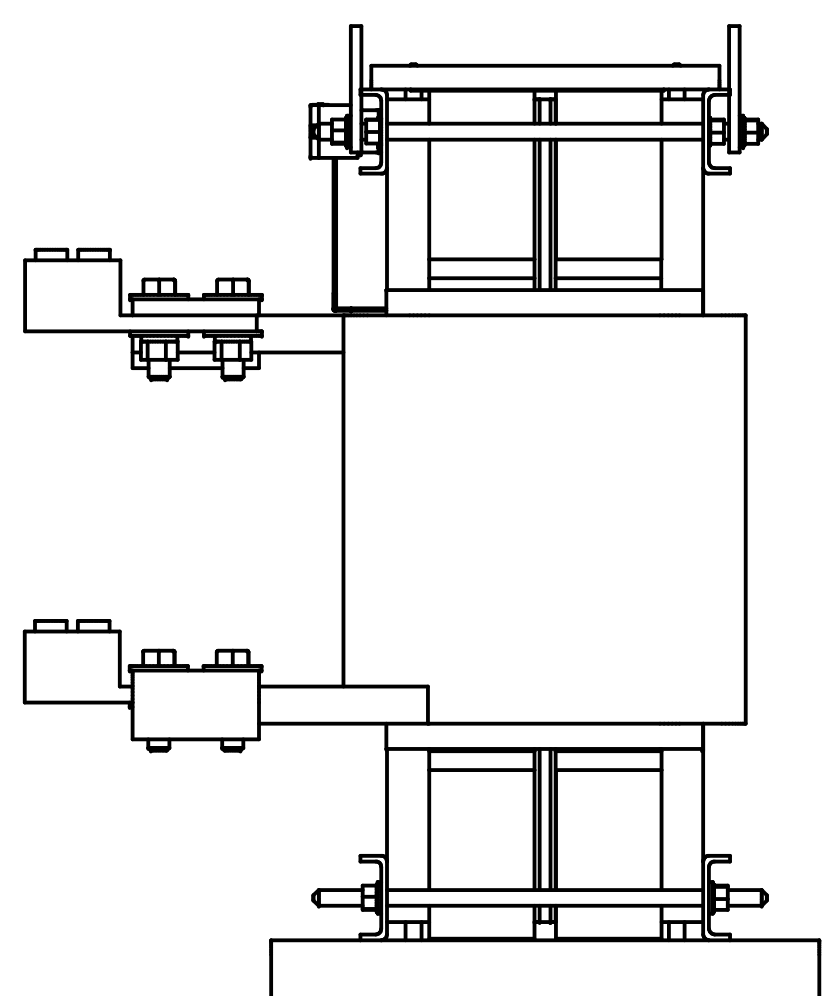
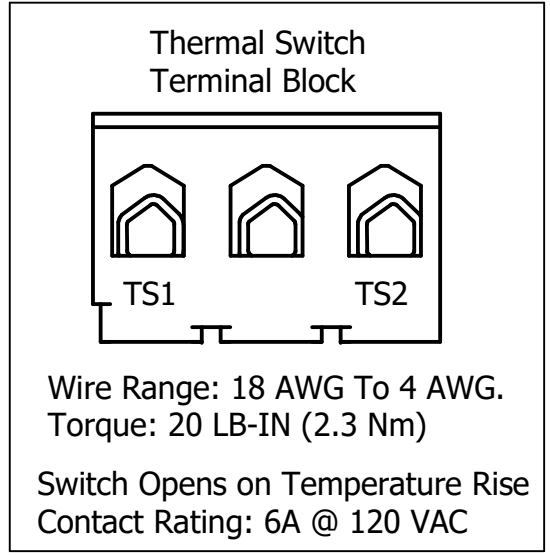
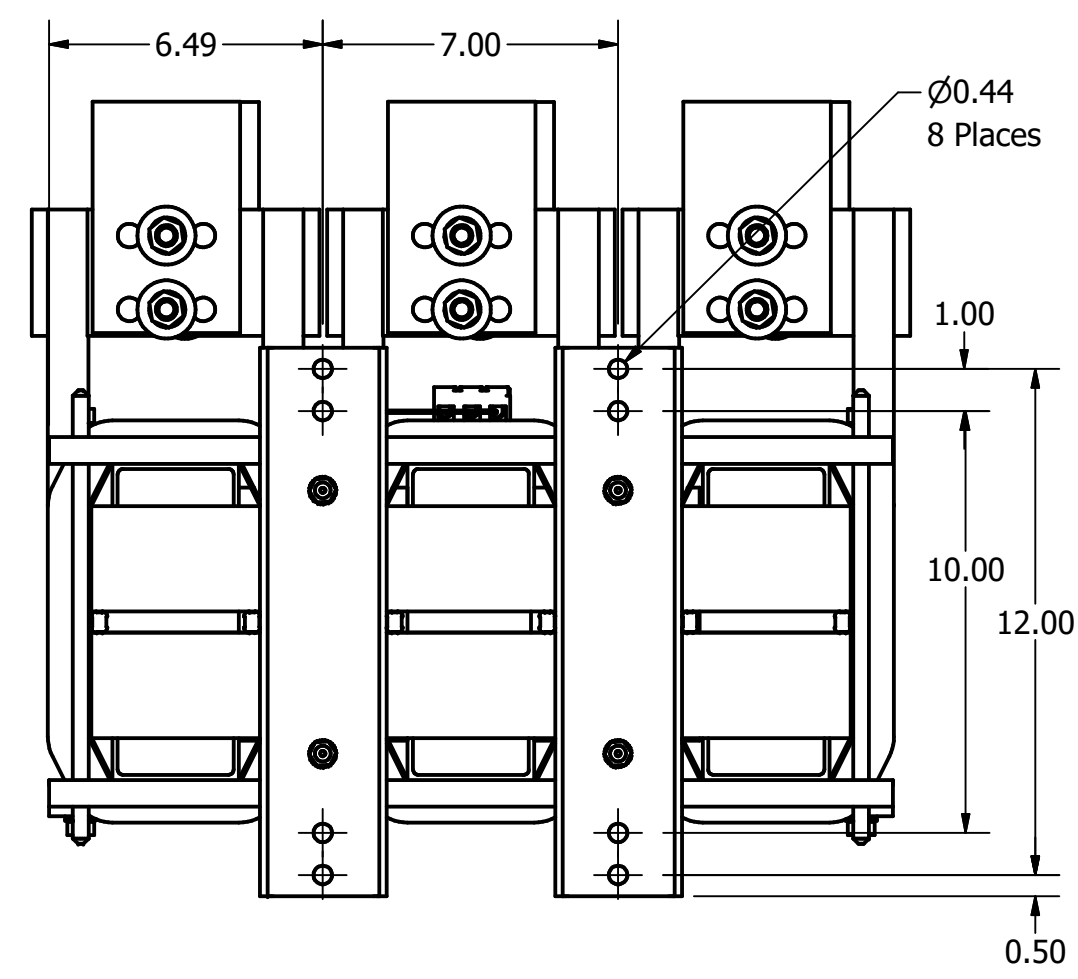
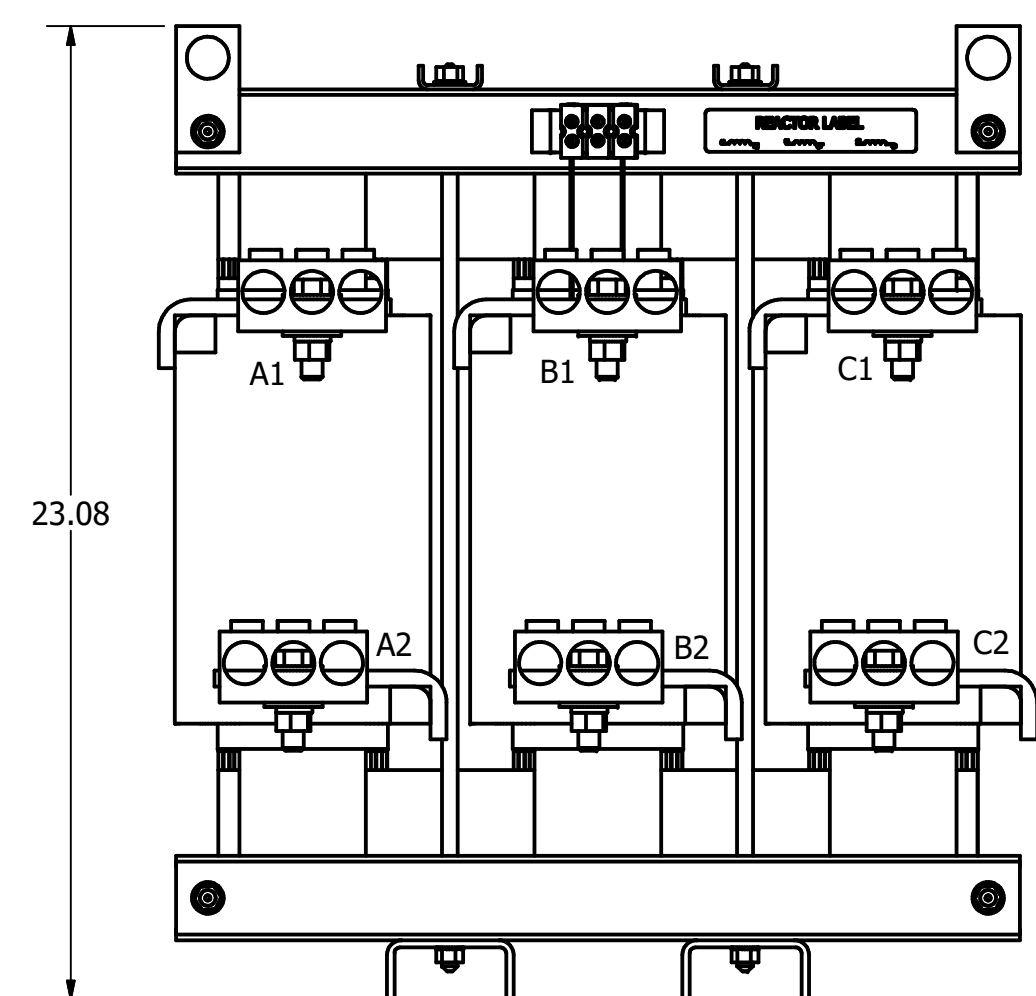
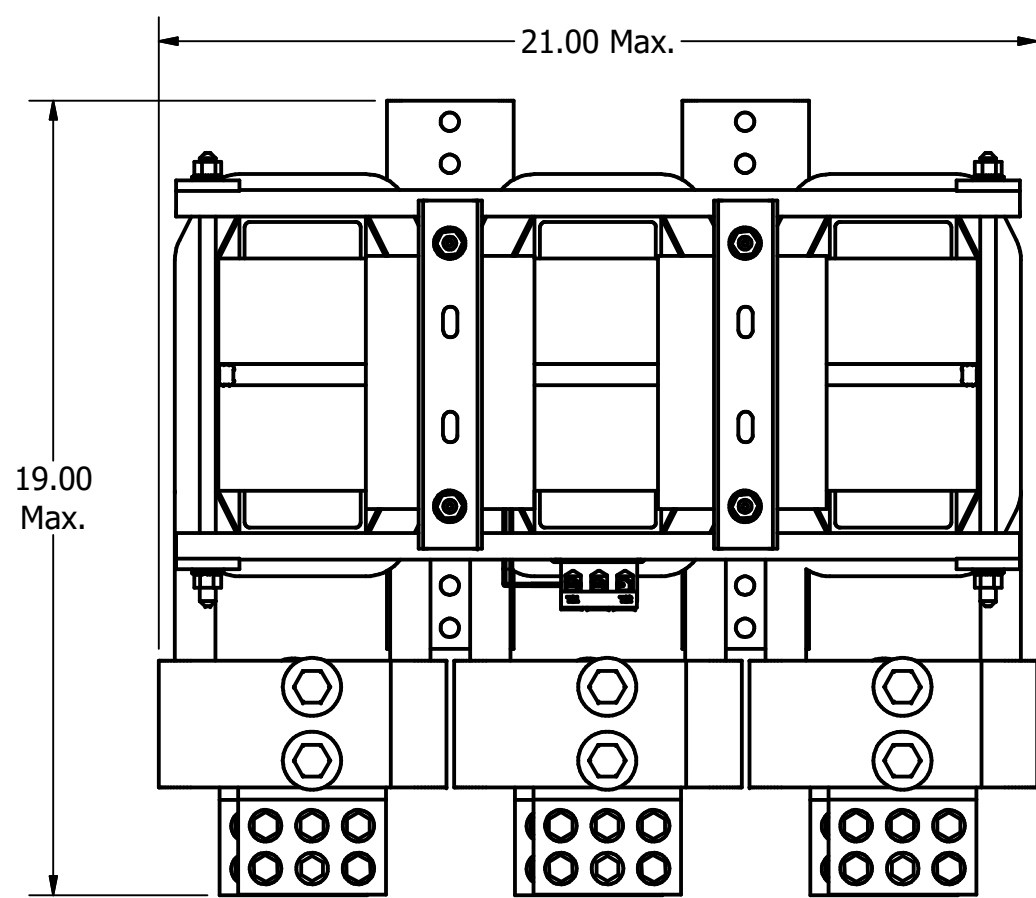

Wire Range	Tightening Torque
600MCM Thru 2 Awg	500 Lbs-In (56.5 N-m)

TCI, LLC
Germantown, WI, USA.
transcoil.com
800-824-8282

(800) 824-8282 transcoil.com

KLRUL Reactor
KLRUL— Motor Amps —
3PH, 50/60Hz, —V Rated, 600V Max, —A Max, RoHS
40C Amb Max
Use 75C CU conductors only, Term Torque—lb-in

UL LISTED
3RD PART. 29, 29840

- Notes:
1. UL file number: cULus Listed File E116124.
 2. KLR Reactors Comply With The Thermal and Altitude Standards Set Forth by NEMA ST20-1992.
 3. Material(s) Shall be RoHS Compliant
 4. Customer Is Responsible For Installation To Meet All National And Local Electrical Codes.

TCI, LLC CLAIMS PROPRIETARY RIGHTS IN THE MATERIAL HEREIN DISCLOSED. IT IS SUPPLIED WITHOUT PREJUDICE TO ANY PATENT RIGHTS OF TCI AND MAY NOT BE REPRODUCED OR USED TO MANUFACTURE ANYTHING SHOWN THEREIN WITHOUT WRITTEN PERMISSION FROM TCI.				TOLERANCES (EXCEPT AS NOTED)		W132 N10611 Grant Drive Germantown, WI 53022 Sinewave Reactor, UL Listed KLRUL750CPTMG, 600V
				DECIMAL		
				.XX ± .25		DRN BY: JRN DATE: 03/17/20 108529DG SCALE: 1/4 APRVD: SIZE: C
				.XXX ± .10		
				FRACTIONAL		SHT. 1 OF 1
				± 1/16		
A	As Designed	03/17/20	JRN	ANGULAR	± 1°	
NO	REVISION	DATE	BY			