

TCI Part Number	Rated Amps (A)	Rated Voltage (V)	Hz	±uH ±5%	Approx Weight (LBS)	Attached Lug Kit
KLRUL850APTMG	850	480	60	57	550	SLK16

Thermal Switch Terminal Block

Wire Range: 18 AWG To 4 AWG.
 Torque: 20 LB-IN (2.3 Nm)
 Switch Opens on Temperature Rise
 Contact Rating: 6A @ 120 VAC

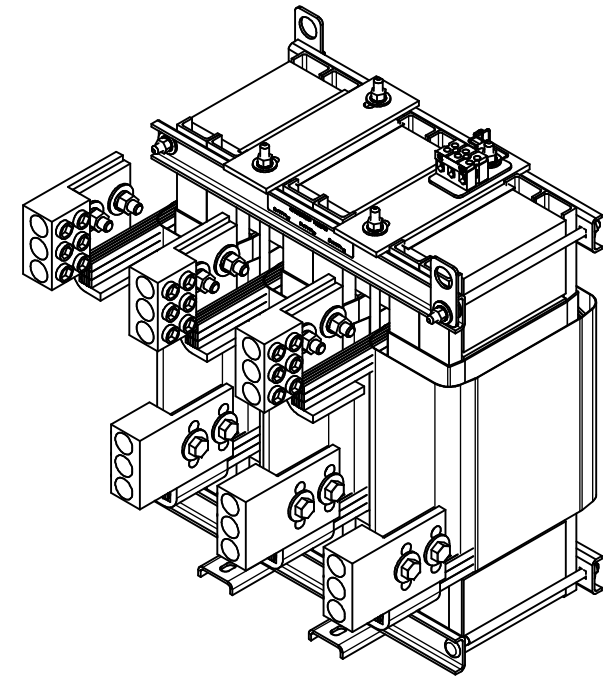
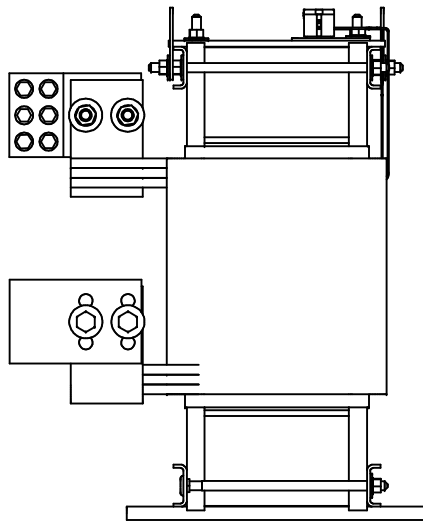

Wire Range	Tightening Torque
600MCM Thru 2 Awg	500 Lbs-In (56.5 N-m)

- Notes:
1. UL file number: cULus Listed File E116124.
 2. KLR Inductors Comply With The Thermal and Altitude Standards Set Forth by NEMA ST20-1992.
 3. Material(s) Shall be RoHS Compliant
 4. Customer Is Responsible For Installation To Meet All National And Local Electrical Codes.

DIMENSIONS IN INCHES (EXCEPT AS NOTED). TOLERANCES (EXCEPT AS NOTED) DECIMAL .XX ± .25 .XXX ± .10 FRACTIONAL ± 1/32 ANGULAR ± 1°	THE INFORMATION AND DESIGN CONTAINED IN THIS DRAWING ARE CONFIDENTIAL AND THE PROPRIETARY PROPERTY OF ALLIENT INC. AND ITS SUBSIDIARIES. NEITHER THIS DESIGN NOR ANY INFORMATION CONTAINED IN THIS DRAWING MAY BE REPRODUCED OR DISCLOSED TO OTHERS WITHOUT THE EXPRESS WRITTEN CONSENT OF ALLIENT INC. AND ITS SUBSIDIARIES.		DESIGNED BY: JRN DATE: 02/24/20		W132N10611 Grant Drive Germantown, WI 53022 © 2025 Allient Inc.
	B 6949 Update Inductor Views 2/18/25 DSW A As Designed 02/24/20 DSW	KLRUL850APTMG Sinewave Inductor With Lugs		SCALE: 1/4 DEN. NO.: 108481DG SIZE: C	SHEET: 1 OF 1