

TCI Part Number	Rated Amps (A)	Rated Voltage (V)	Hz	---uH ±5%	Approx Weight (LBS)	Attached Lug Kit
KLRUL480APTMG	480	480	60	100	455	SLK14
KLRUL540APTMG	540	480	60	90	450	SLK14
KLRUL600APTMG	600	480	60	80	450	SLK14

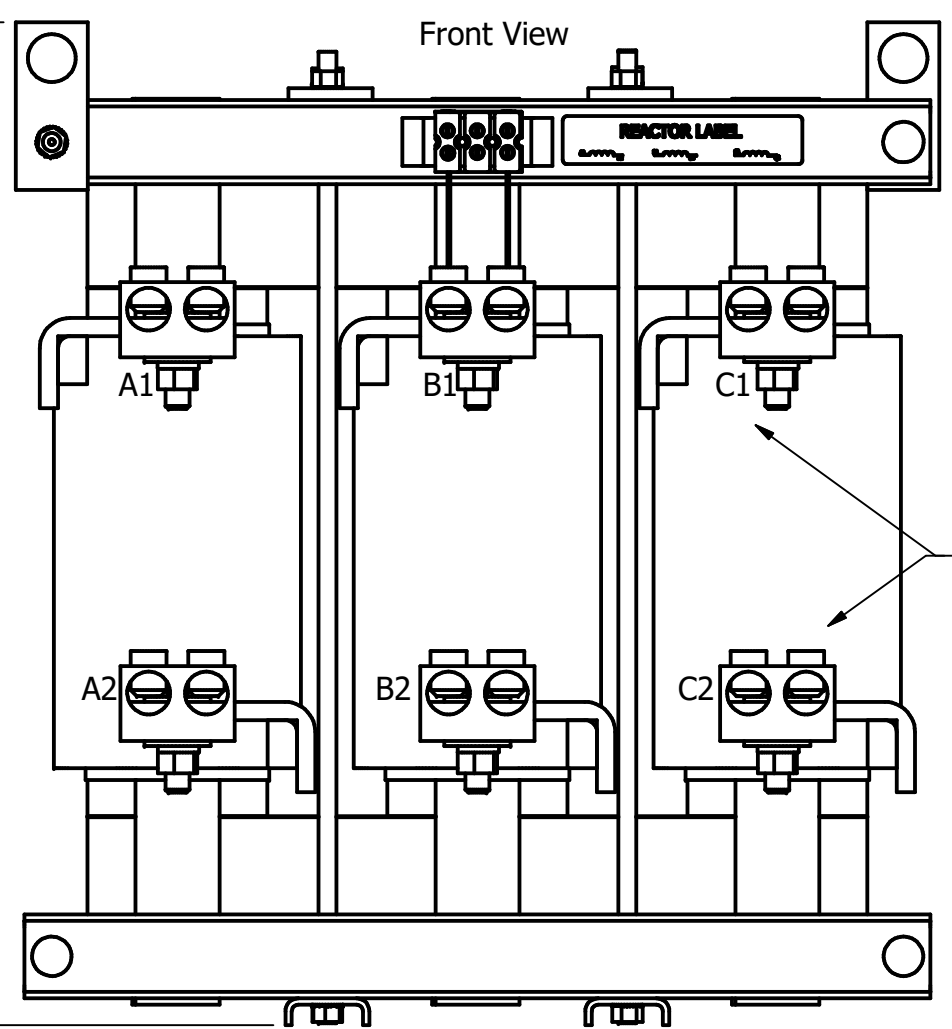

Markings on coil for reference only.

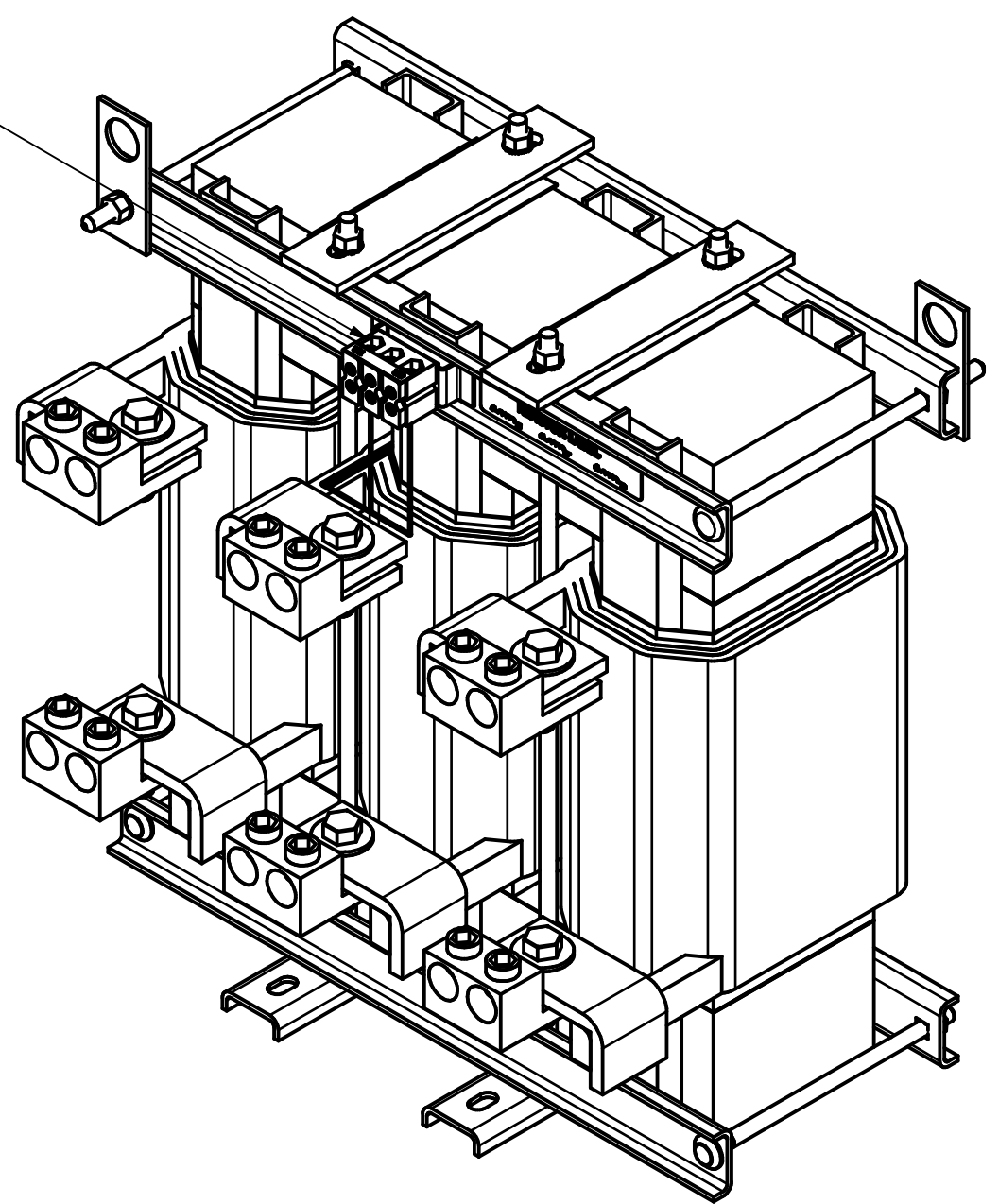
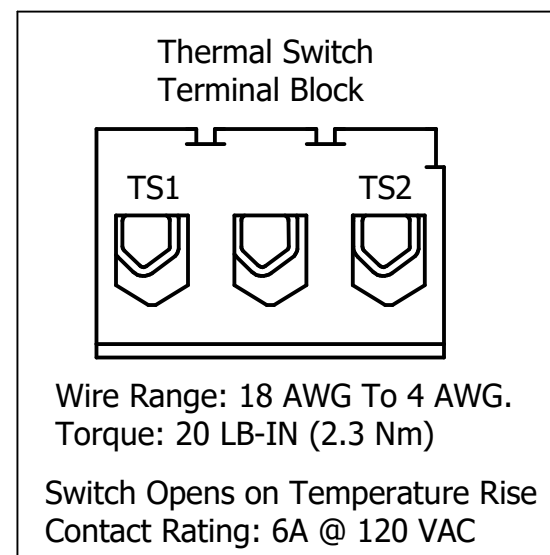
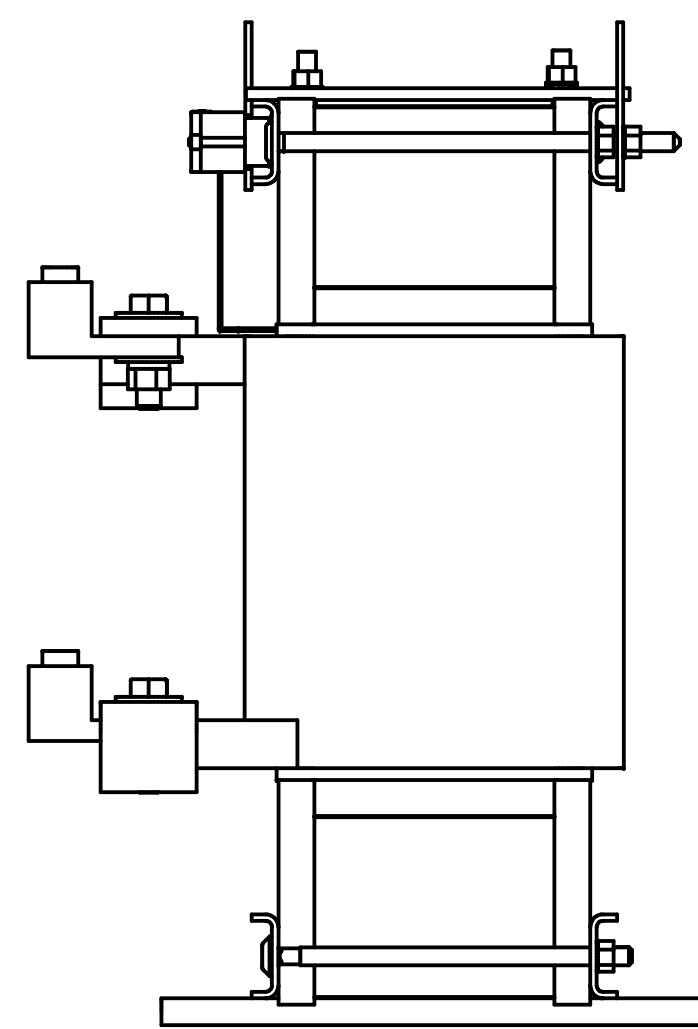

Wire Range	Tightening Torque
600MCM Thru 4 Awg	500 Lbs-In (56.5 N-m)

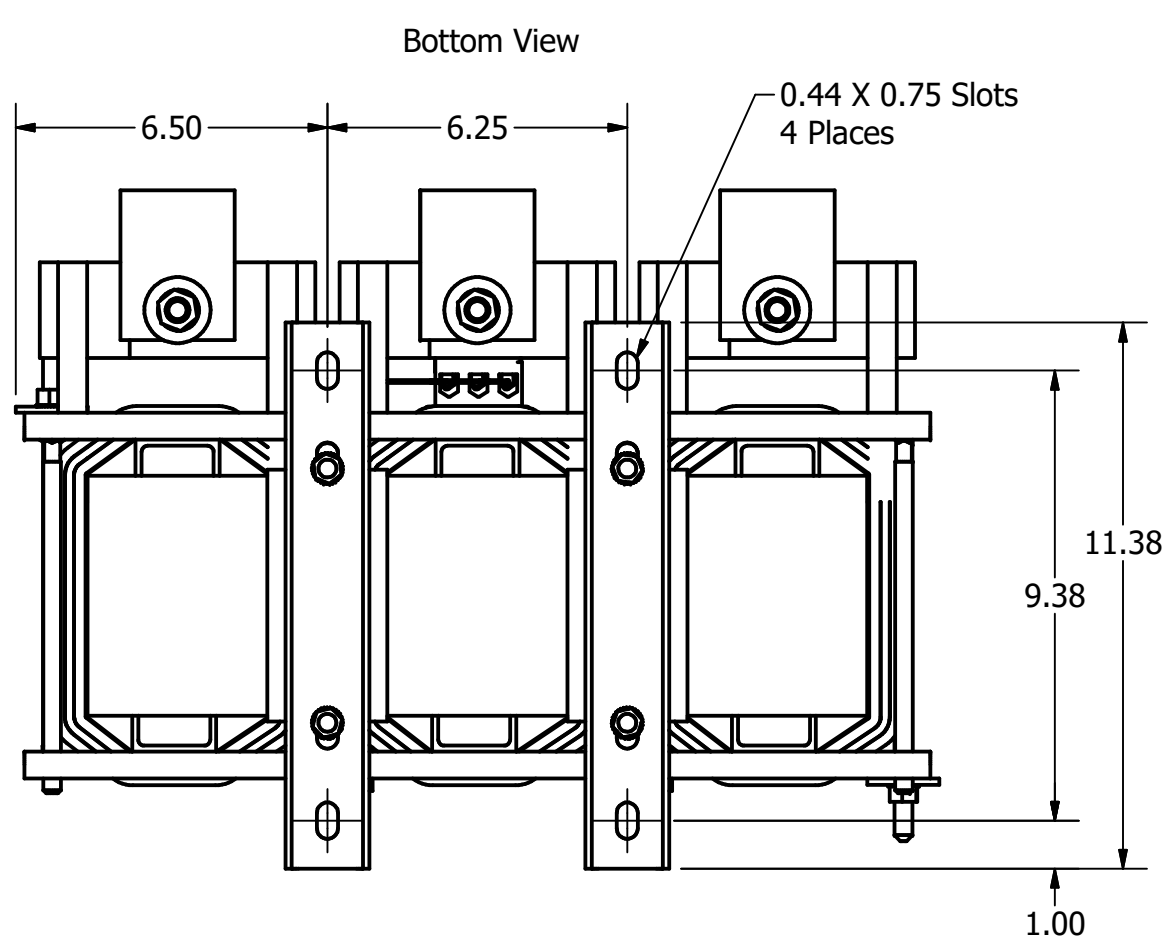

TCI
TCI, LLC
Germantown, WI, USA.
transcoil.com
800-824-8282

(800) 824-8282 transcoil.com

KLRUL Reactor
KLRUL— Motor Amps —
3PH, 50/60Hz, —V Rated, 600V Max, —A Max, RoHS
40C Amb Max, RoHS
Use 75C CU conductors only, Term Torque—lb-in

UL LISTED
3RD PART. 29, 2999

- Notes:
1. UL file number: cULus Listed File E116124.
 2. KLR Reactors Comply With The Thermal and Altitude Standards Set Forth by NEMA ST20-1992.
 3. Material(s) Shall be RoHS Compliant
 4. Customer Is Responsible For Installation To Meet All National And Local Electrical Codes.

TCI, LLC CLAIMS PROPRIETARY RIGHTS IN THE MATERIAL HEREIN DISCLOSED. IT IS SUPPLIED WITHOUT PREJUDICE TO ANY PATENT RIGHTS OF TCI AND MAY NOT BE REPRODUCED OR USED TO MANUFACTURE ANYTHING SHOWN THEREIN WITHOUT WRITTEN PERMISSION FROM TCI.				TOLERANCES (EXCEPT AS NOTED)		TCI W132 N10611 Grant Drive Germantown, WI 53022
				DECIMAL		
				.XX ± .25 .XXX ± .10		DRN BY JRN DATE 02/25/20 108479DG
				FRACTIONAL ± 1/16		
A As Designed		02/25/20	JRN	ANGULAR ± 1°		SCALE 1/4
NO REVISION		DATE	BY			SIZE C