

UNIT SPECIFICATIONS

KVAR	HARMONIC	VOLT	Hz	PHASE	HP	AMPS
60	5TH	480	60	3	500	590

SCHEMATIC : 30586-PQ6

GROUND LUG:

WIRE RANGE - FIVE 2/0-14AWG
TIGHTENING TORQUE 50 LB-IN.

L1 L2 L3 T1 T2 T3
CUSTOMER CONNECTIONS:

WIRE RANGE - THREE 600MCM-2
TIGHTENING TORQUE 500 LB-IN.

Notes:

1. Customer is responsible for installation to meet all national and local electrical codes.
2. Use only hubs or fittings that comply with UL514B for type 3R enclosures.
3. Approx. WT LBS : 850
4. Enclosure Color: ANSI-61 Gray
5. PQconnect Programming Model: Custom Unit HGL0500AWxC1xxxELC

Top View

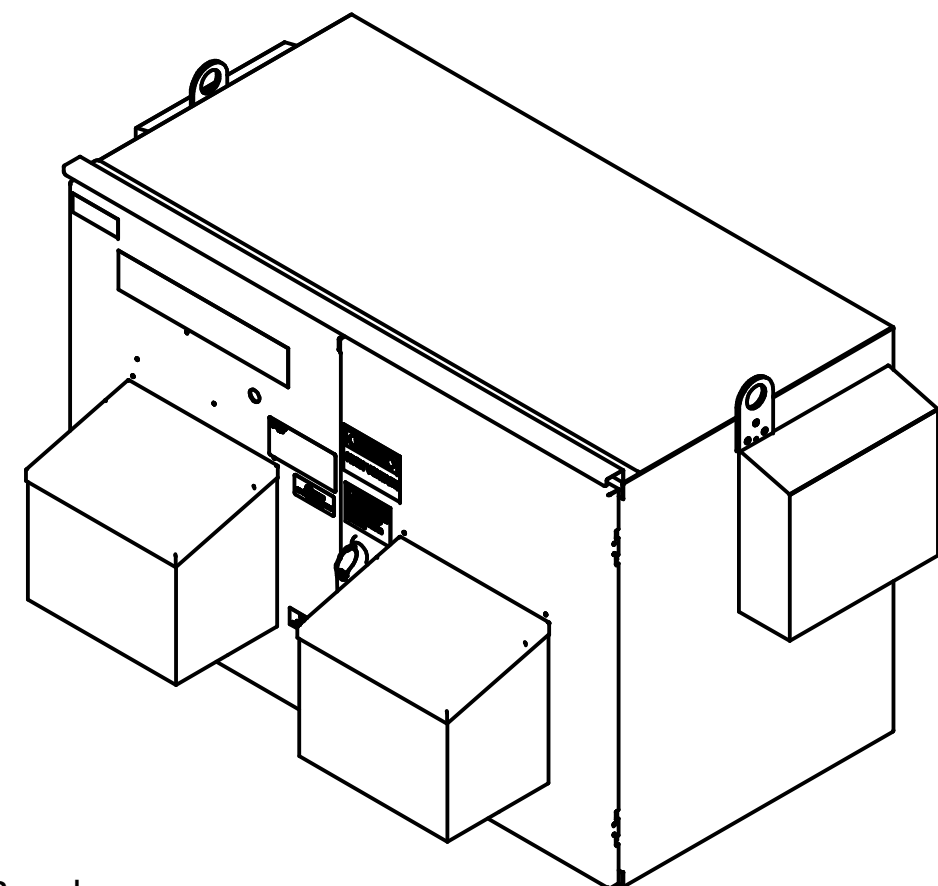
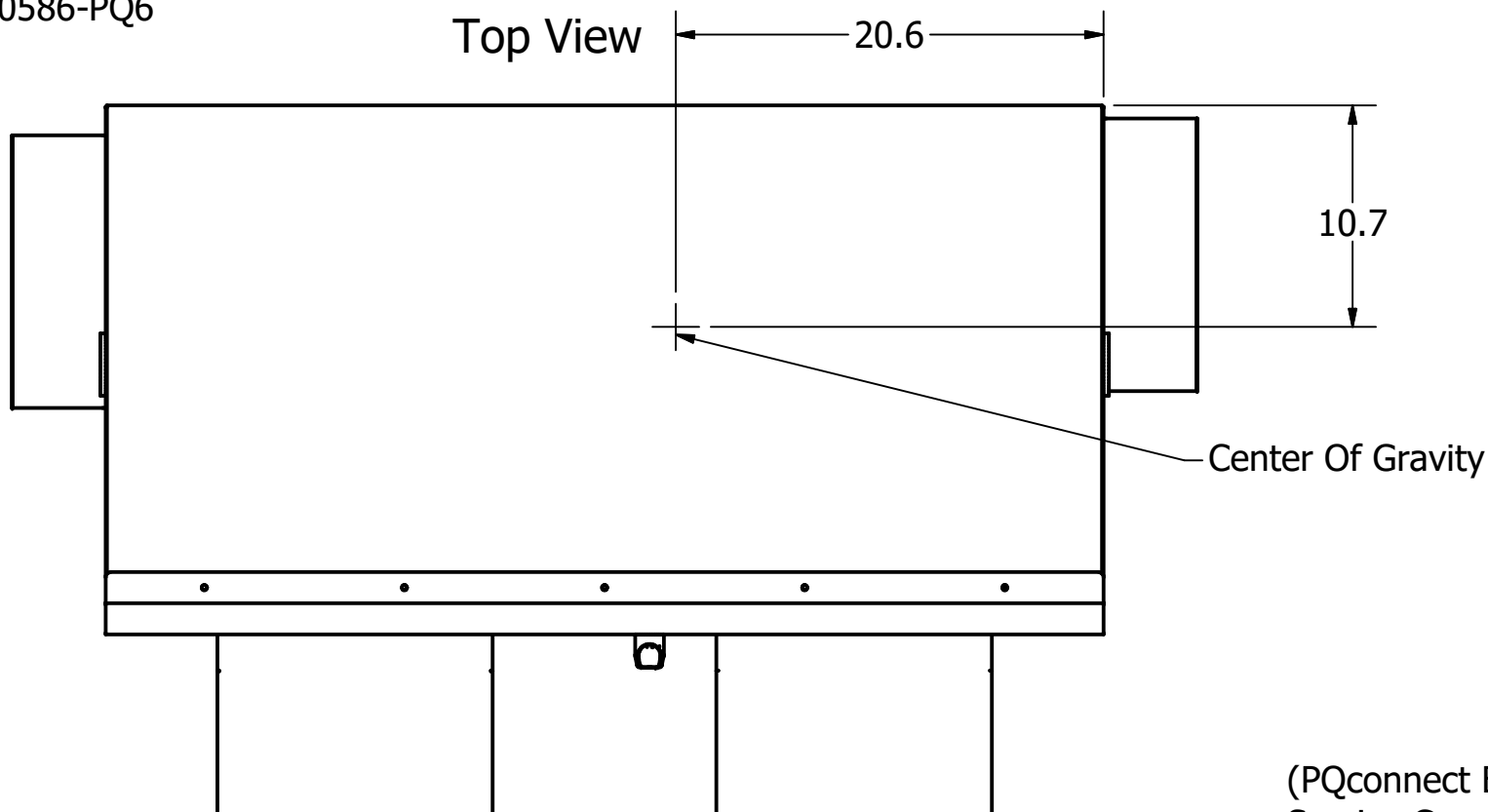

(PQconnect Board Service Connection Port)

Front View Without Doors

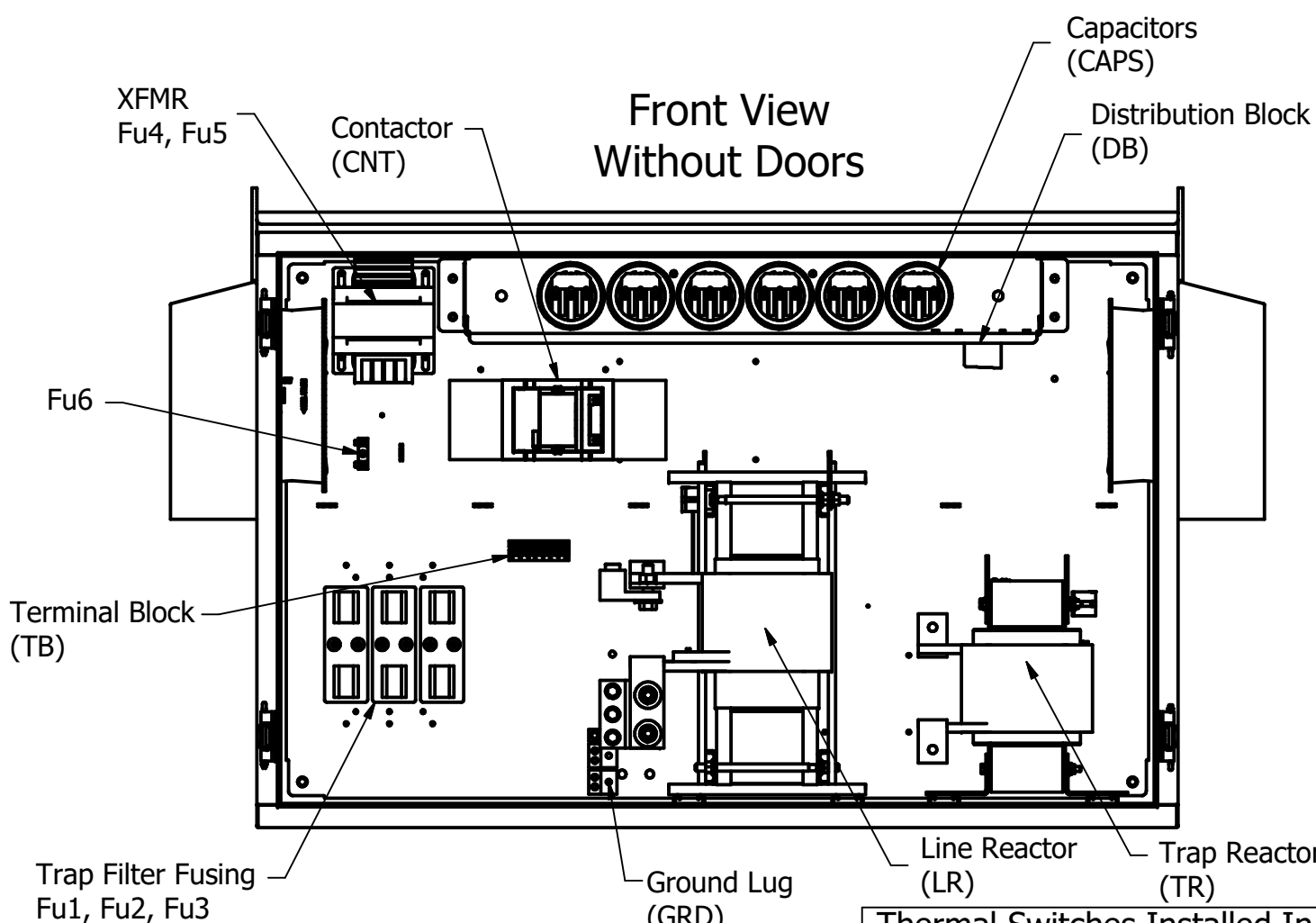

Thermal Switches Installed In Line Reactor And Tuning Reactor Wired To PQconnect For Monitoring

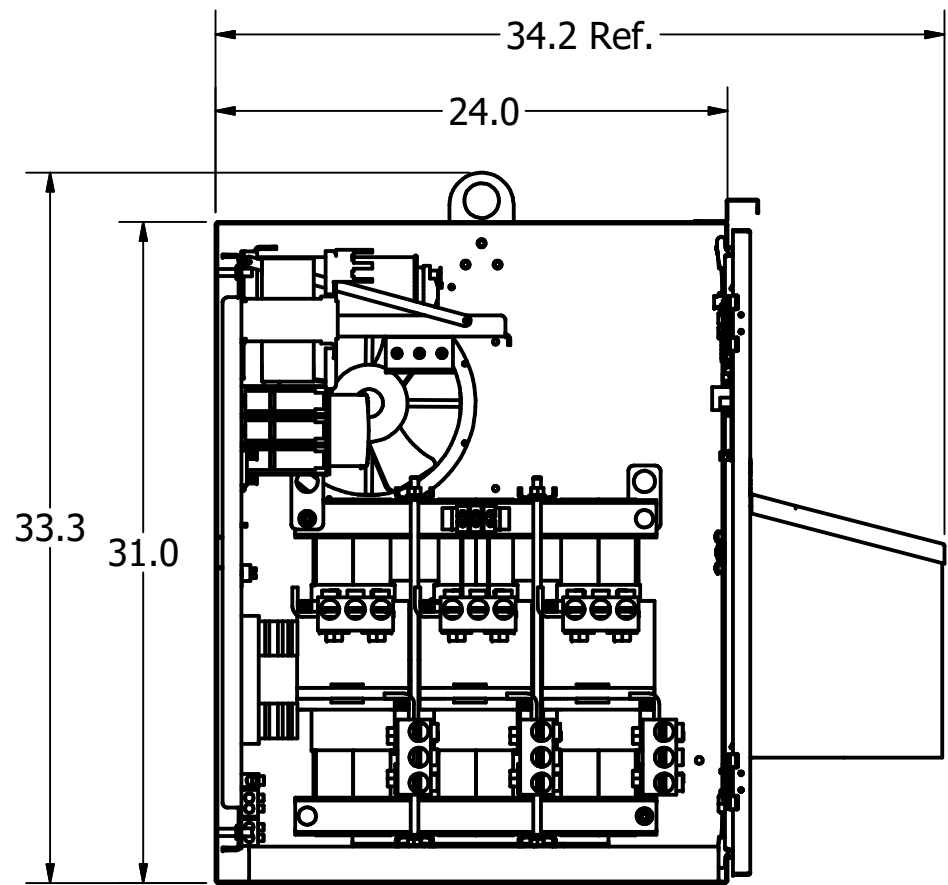
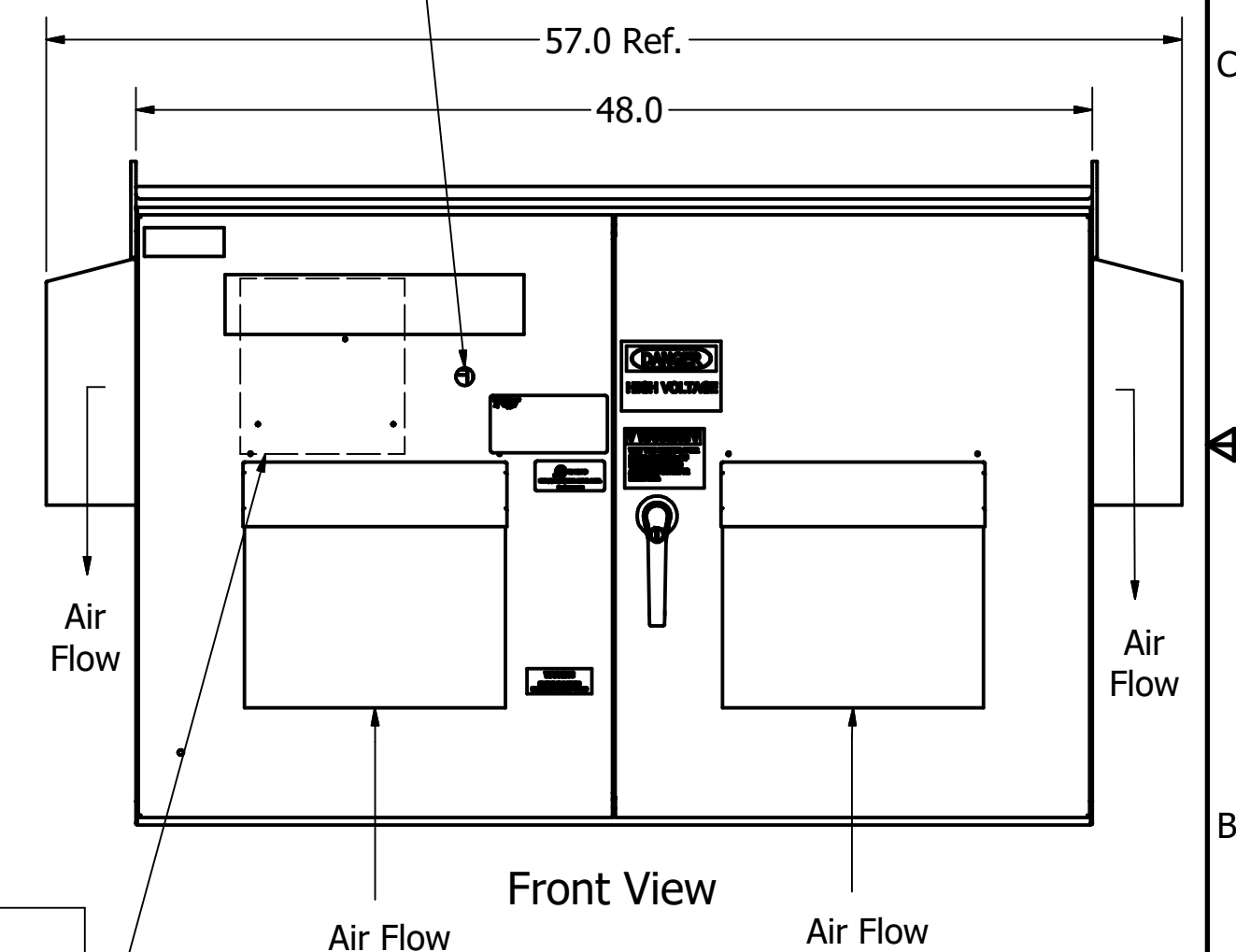

Side View Without Wall

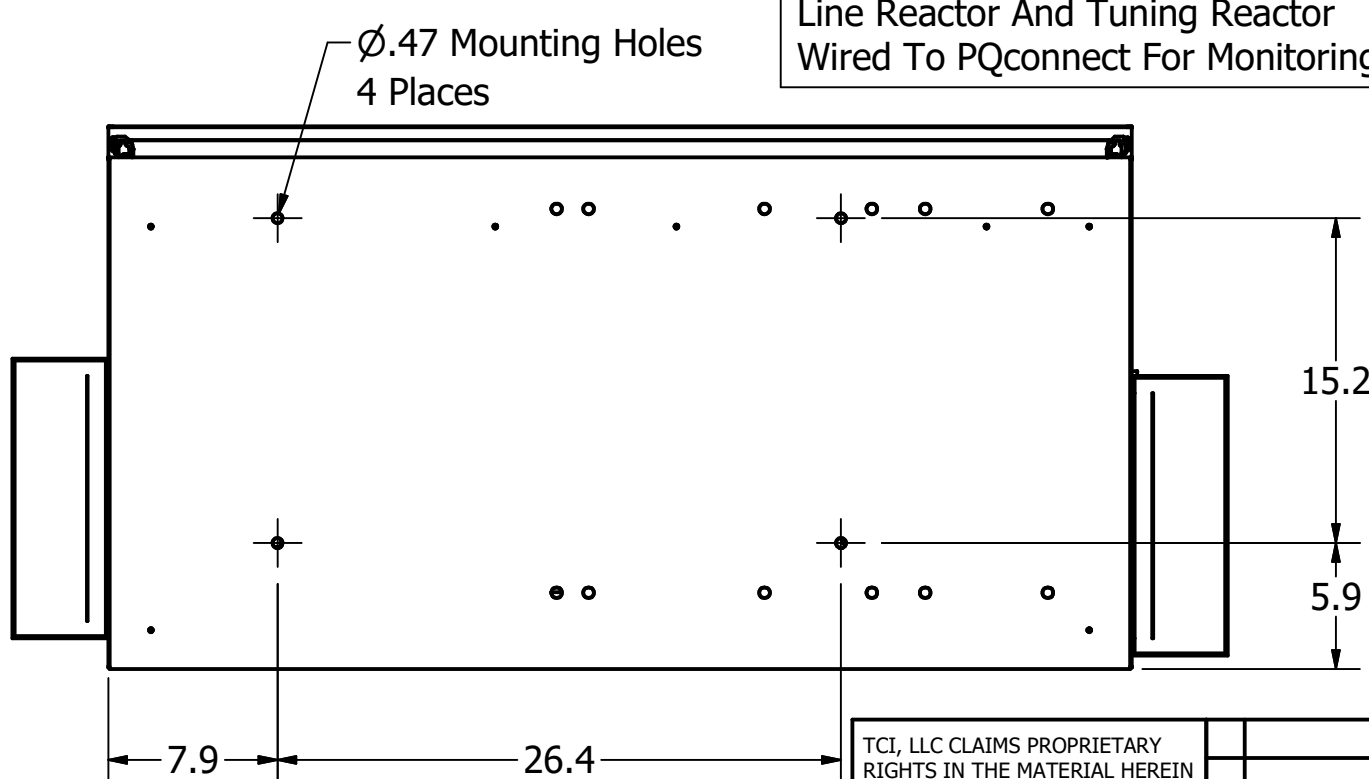

Bottom View

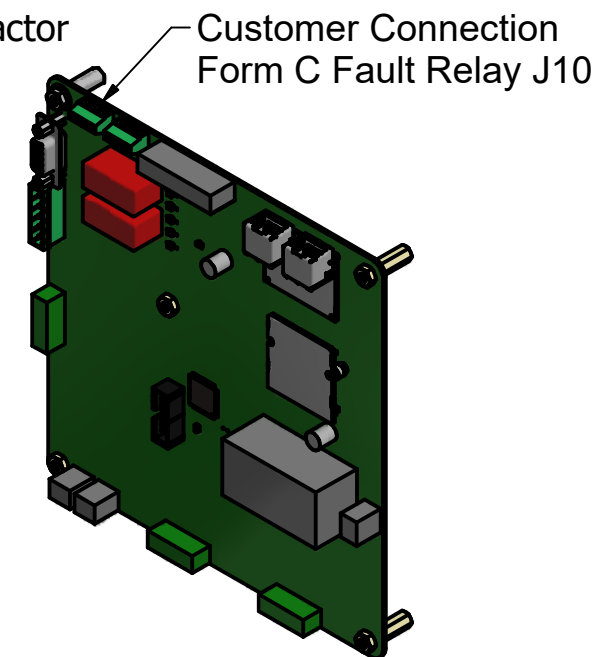

TCI, LLC CLAIMS PROPRIETARY RIGHTS IN THE MATERIAL HEREIN DISCLOSED. IT IS SUPPLIED WITHOUT PREJUDICE TO ANY PATENT RIGHTS OF TCI AND MAY NOT BE REPRODUCED OR USED TO MANUFACTURE ANYTHING SHOWN THEREIN WITHOUT WRITTEN PERMISSION FROM TCI.

REVISION	DATE	BY	TOLERANCES (EXCEPT AS NOTED)
D	03/15/23	JRN	.XX ± .25
C	09/29/20	JRN	.XXX ± .10
B	09/06/19	JRN	FRACTIONAL ± 1/16
A	07/23/19	JRN	ANGULAR ± 1°
NO			

TCI W132 N10611 Grant Drive
Germantown, WI 53022

Multistack, HGL, 500HP, 480/3/60
Type 3R, CNT, PQconnect, Low Profile
Enclosure, 2 Tsw, Spcl Low C

DRN BY JRN DATE 07/23/19 108211DG
SCALE 1/9 APRVD: SIZE C SHT 1 OF 1