

4

3

2

1

GROUND LUG:

WIRE RANGE - TWO 600MCM-2
TIGHTENING TORQUE 500 IN-LB.

L1 L2 L3 T1 T2 T3
CUSTOMER CONNECTIONS:

WIRE RANGE - TWO 600MCM-2
TIGHTENING TORQUE 500 IN-LB.

- Notes:
1. Customer is responsible for installation to meet all national and local electrical codes.
 2. Use only hubs or fittings that comply with UL514B for type 3R enclosures.
 3. Approx. WT LBS : 850
 4. Enclosure Color: RAL 7006 Beige Grey.
 5. Filter Configured With Dry Capacitors.

UNIT SPECIFICATIONS						
KW	VOLT	PHASE	HZ	HARMONIC	KVAR	AMPS
250	380-415	3	50	5TH	51	470

SCHEMATIC : 31582-60 Top View

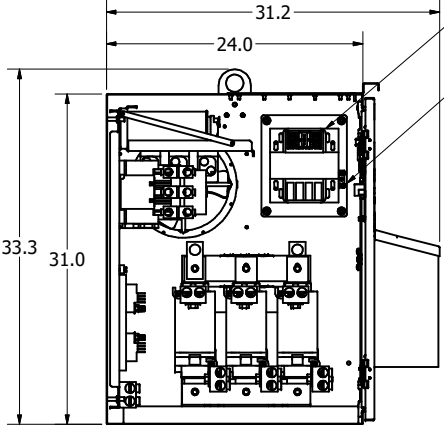
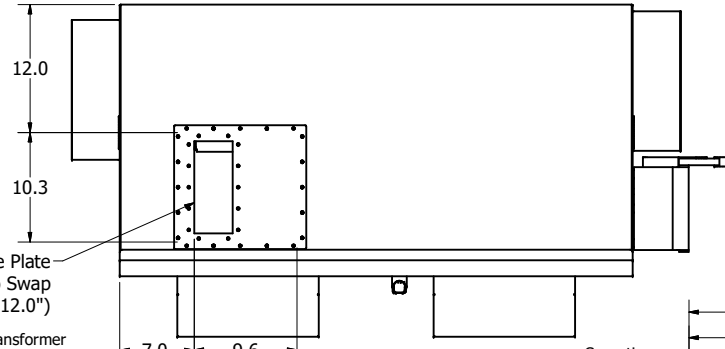
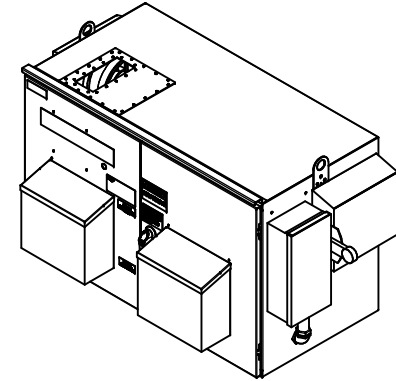

Side View Without Wall

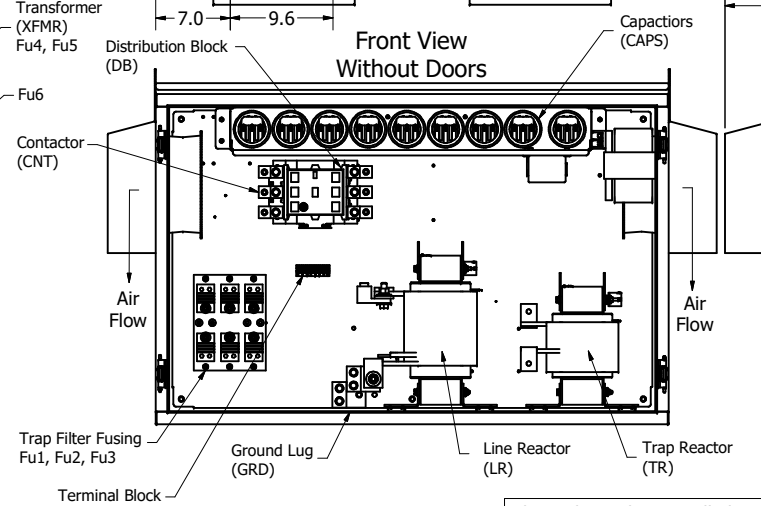

Front View Without Doors

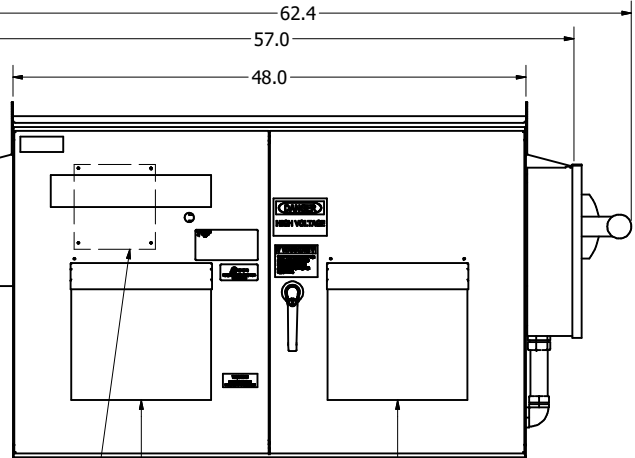

Front View

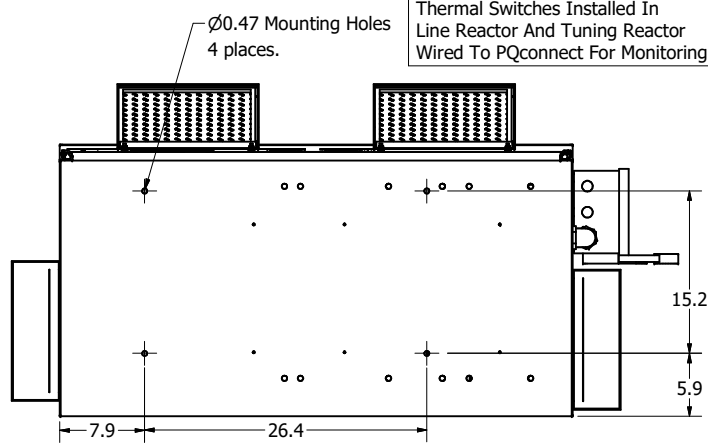

Bottom View

PQconnect Contactor Control Board Mounted To Inside Of Door

Customer Connection Form C Fault Relay J10

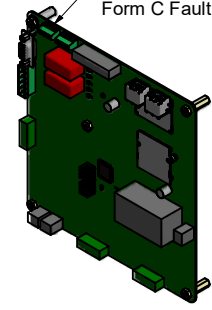

THE INFORMATION AND DESIGNS CONTAINED IN THIS DRAWING ARE CONFIDENTIAL AND THE PROPRIETARY PROPERTY OF ALLIED MOTION TECHNOLOGIES INC. AND ITS SUBSIDIARIES. NEITHER THIS DESIGN NOR ANY INFORMATION CONTAINED IN THIS DRAWING MAY BE REPRODUCED OR DISCLOSED TO OTHERS WITHOUT THE EXPRESS WRITTEN CONSENT OF ALLIED MOTION TECHNOLOGIES INC. AND ITS SUBSIDIARIES.

NO	REVISION	DATE	BY
A	As Designed	05/04/21	JRN

TOLERANCES (EXCEPT AS NOTED)	
DECIMAL	.XX ± .25 .XXX ± .10
FRACTIONAL	± 1/32
ANGULAR	± 1°

TCL W132N10611 Grant Drive
Germanstown, WI 53022
© 2021 TCL, LLC

An Official Motion Company

HarmonicGuard Low Capacitance, 250kW
380-415/3/50, Type 3R, JCL, 60A Fused Disconnect

DWG. BY: JRN DATE: 05/04/21 108203-01DG
SCALE: 1/9 REVISED: FILE: SHEET 1 OF 1

4

3

2

1