

0.56 Dia Holes  
4 Per Terminal.

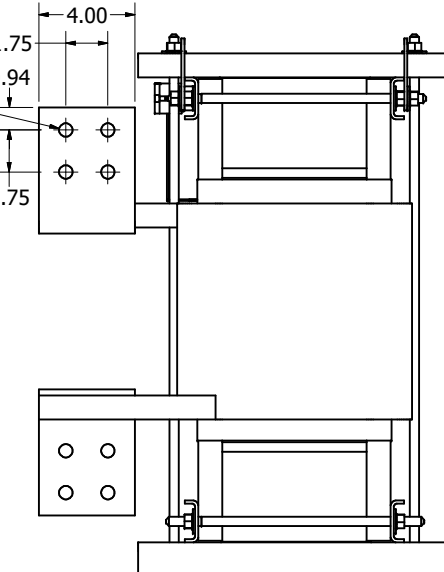

**Thermal Switch Terminal Block**

Wire Range: 18 AWG To 4 AWG.  
Torque: 20 LB-IN (2.3 Nm)

Switch Opens on Temperature Rise  
Contact Rating: 6A @ 120 VAC

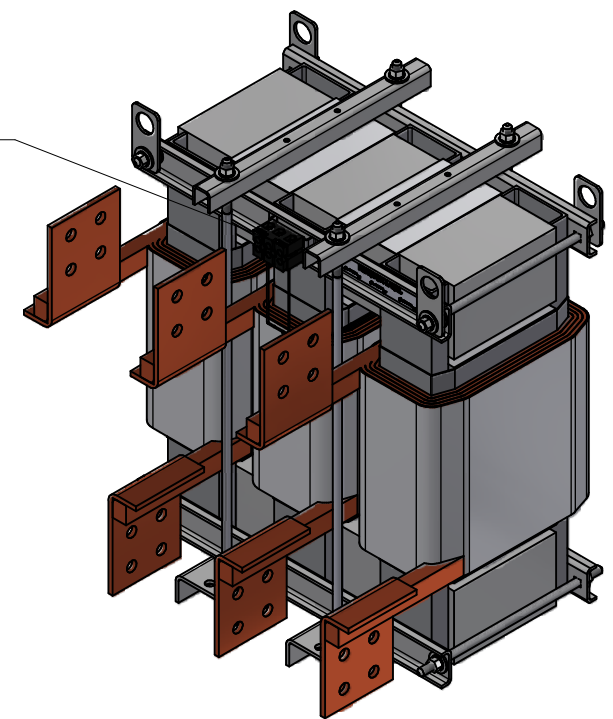

TCI Part#	Amps Max. (A)	mH+/-5%	Approx Weight (LBS)	Available Lug Kit
KTRMG750AX2	750	0.064	575	SLK16-1

NO	REVISION	DATE	BY	SCALE	1/4	DATE	6/25/18	DATE	6/25/18	107771DG
E	6768, Adding Thermal Switch Instruction	8/19/2024	DSW							
E	Sheet to shop Drawing	8/19/2024	DSW							
D	6740, Thermal Switch Moved	7/24/2024	DSW							
C	6216, 4132 to 31621-1 Lift ring	3/24/2023	DSW							
B	4810, Add Thermo Switch	7/18/19	DSW							
A	As Designed	6/25/18	DSW							

Customer Is Responsible For Installation to Meet All National And Local Electrical Codes.

Material(s) Shall be RoHS Compliant

THE INFORMATION AND DESIGNS CONTAINED IN THIS DRAWING ARE CONFIDENTIAL AND THE PROPRIETARY PROPERTY OF ALLIED MOTION TECHNOLOGIES INC. AND ITS SUBSIDIARIES. NEITHER THIS DESIGN NOR ANY INFORMATION CONTAINED IN THIS DRAWING MAY BE REPRODUCED OR DISCLOSED TO OTHERS WITHOUT THE EXPRESS WRITTEN CONSENT OF ALLIED MOTION TECHNOLOGIES INC. AND ITS SUBSIDIARIES.