

HP	Volts	Phase	Hz.	Harmonic	Kvar	Contactor	Weight
60	600	3	60	5TH	19.8	Without	185lbs
60	600	3	60	5TH	19.8	With	188lbs

CUSTOMER CONNECTIONS
 L1, L2,L3, T1, T2, T3
 WIRE RANGE: #4 TO #22 AWG.
 GROUND LUG
 WIRE RANGE: #1/0 TO #14 AWG.

SEE IOM MANUAL FOR WIRE TORQUES.
 FOR SCHEMATIC SEE DRAWING# 30047

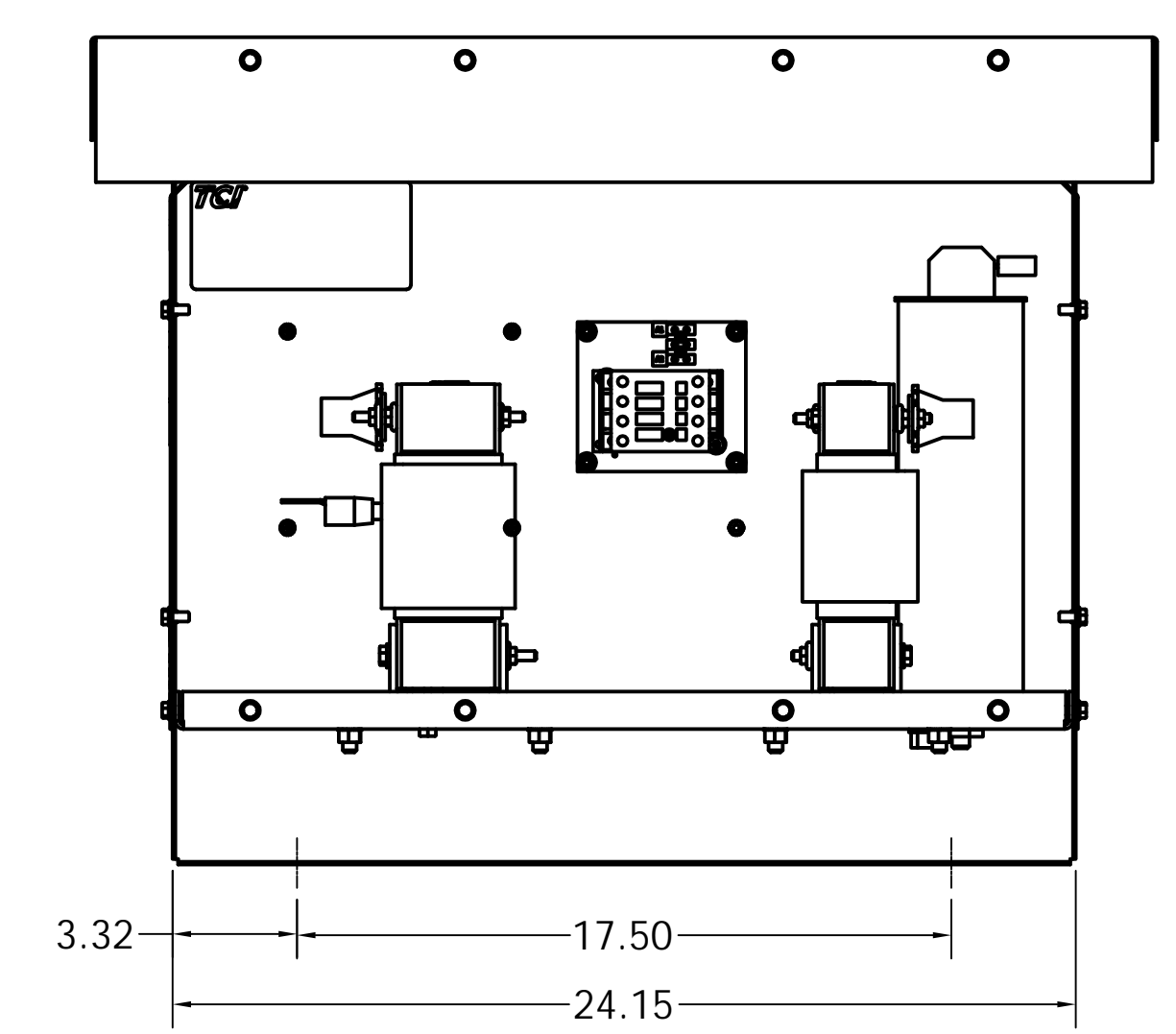
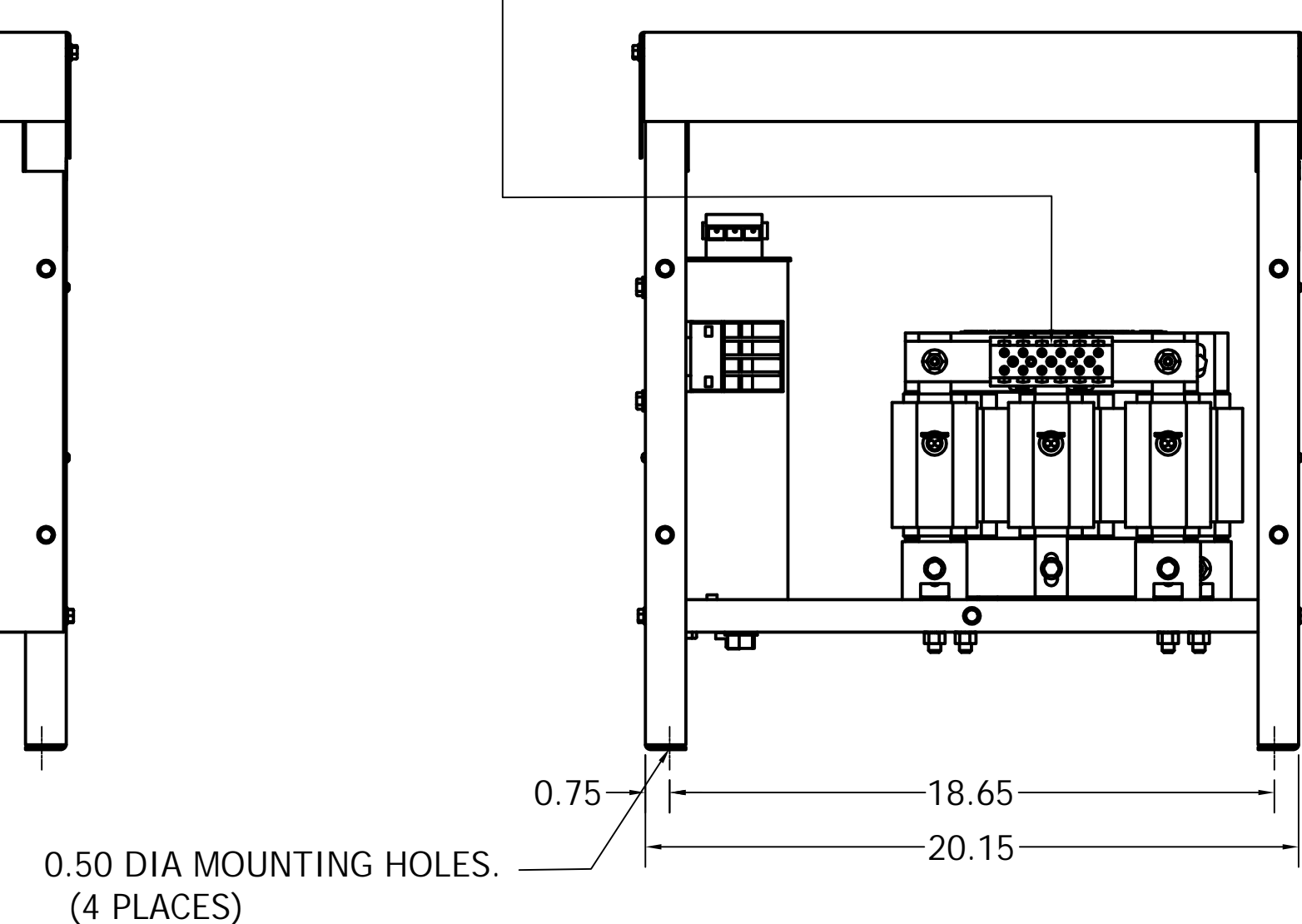

CUSTOMER IS RESPONSIBLE FOR INSTALLATION TO MEET ALL NATIONAL AND LOCAL ELECTRICAL CODES.

NOTE: USE ONLY HUBS OR FITTINGS THAT COMPLY WITH UL514B FOR TYPE 3R ENCLOSURES.

TOLERANCES (EXCEPT AS NOTED)			
DECIMAL			
.XX	+/- .25		
.XXX	+/- .1		
FRACTIONAL			
	+/- 1/16		
ANGULAR			
	+/- 1°		

NO	REVISION	DATE	BY
A	AS DESIGNED	7/22/16	DSW

TCI® W132 N10611 Grant Drive
 Germantown, WI 53022

**HARMONIC SHIELD, 600V
 60HP**

DRN. BY DSW	DATE 7/22/16	DWG. No. 106601DG
SCALE 1/5	APRVD.	SHEET 1 OF 1

A

4

3

4

2

1

A