

HP	Volts	Phase	Hz.	Harmonic	Kvar	Contactors	Weight
25	600	3	60	5TH	8.3	Without	93lbs
25	600	3	60	5TH	8.3	With	96lbs
30	600	3	60	5TH	10	Without	102lbs
30	600	3	60	5TH	10	With	105lbs
40	600	3	60	5TH	9.9	Without	143lbs
40	600	3	60	5TH	9.9	With	146lbs
50	600	3	60	5TH	14.9	Without	143lbs
50	600	3	60	5TH	14.9	With	146lbs

CUSTOMER CONNECTIONS:
SEE IOM MANUAL FOR WIRE SIZE AND TORQUES.
FOR SCHEMATIC SEE DRAWING# 30047

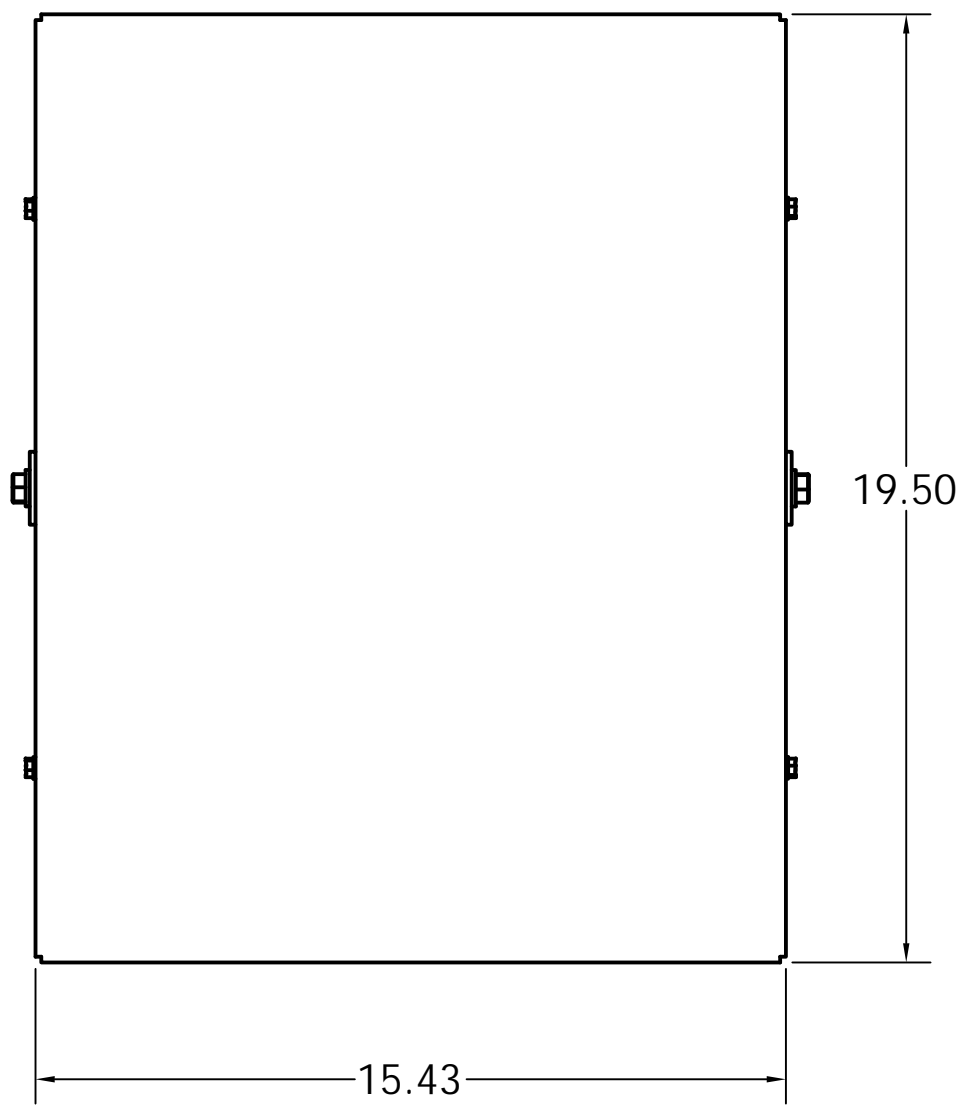

CONTACTOR (CNT)
{OPTIONAL}
TERMINAL BLOCK (TB)
{INCLUDED WITH OPTIONAL CONTACTOR}

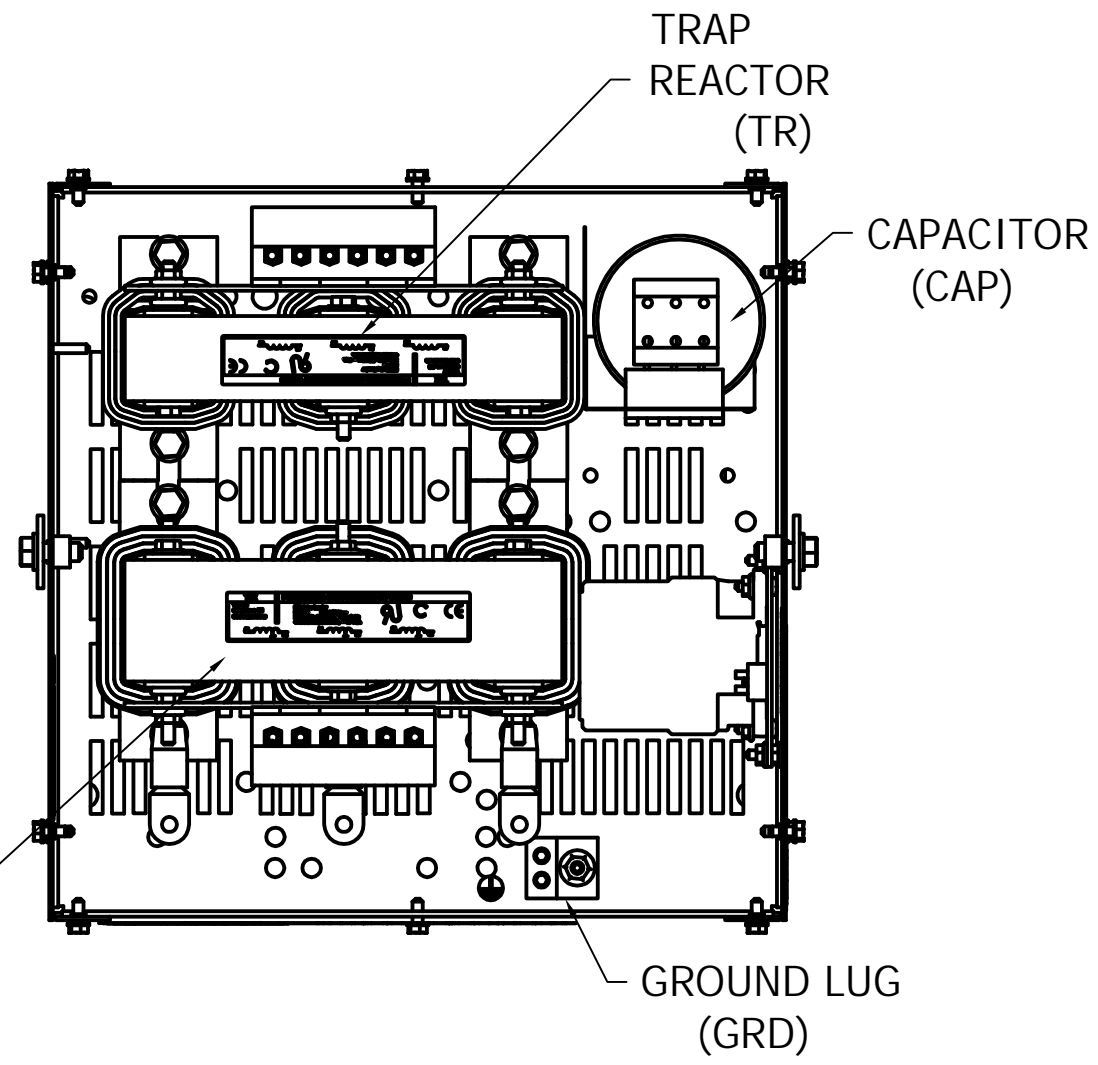
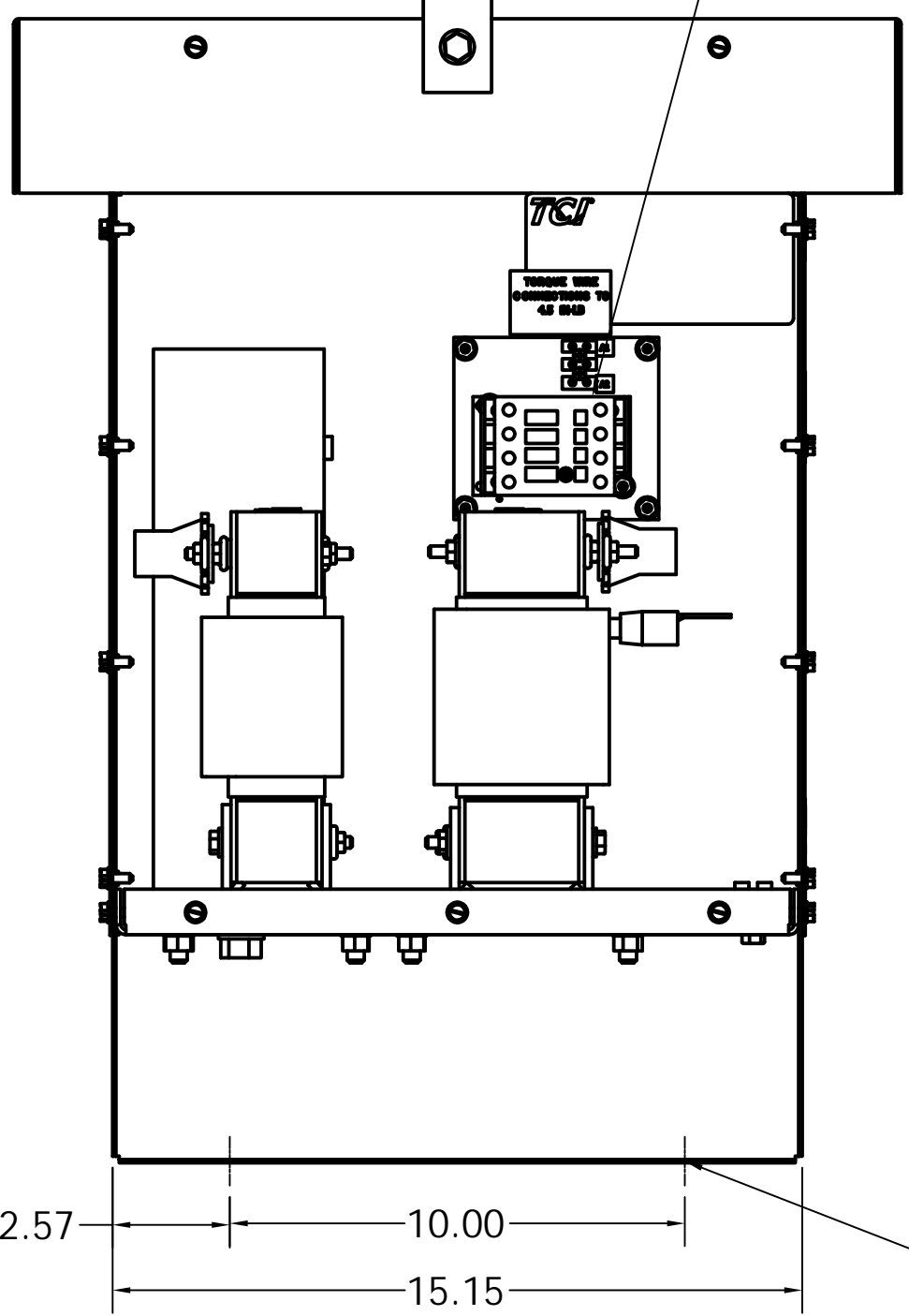

L1, 2L, L3, T1, T2, T3
SUGGESTED CUSTOMER WIRE
ENTRY AND EXIT LOCATION.

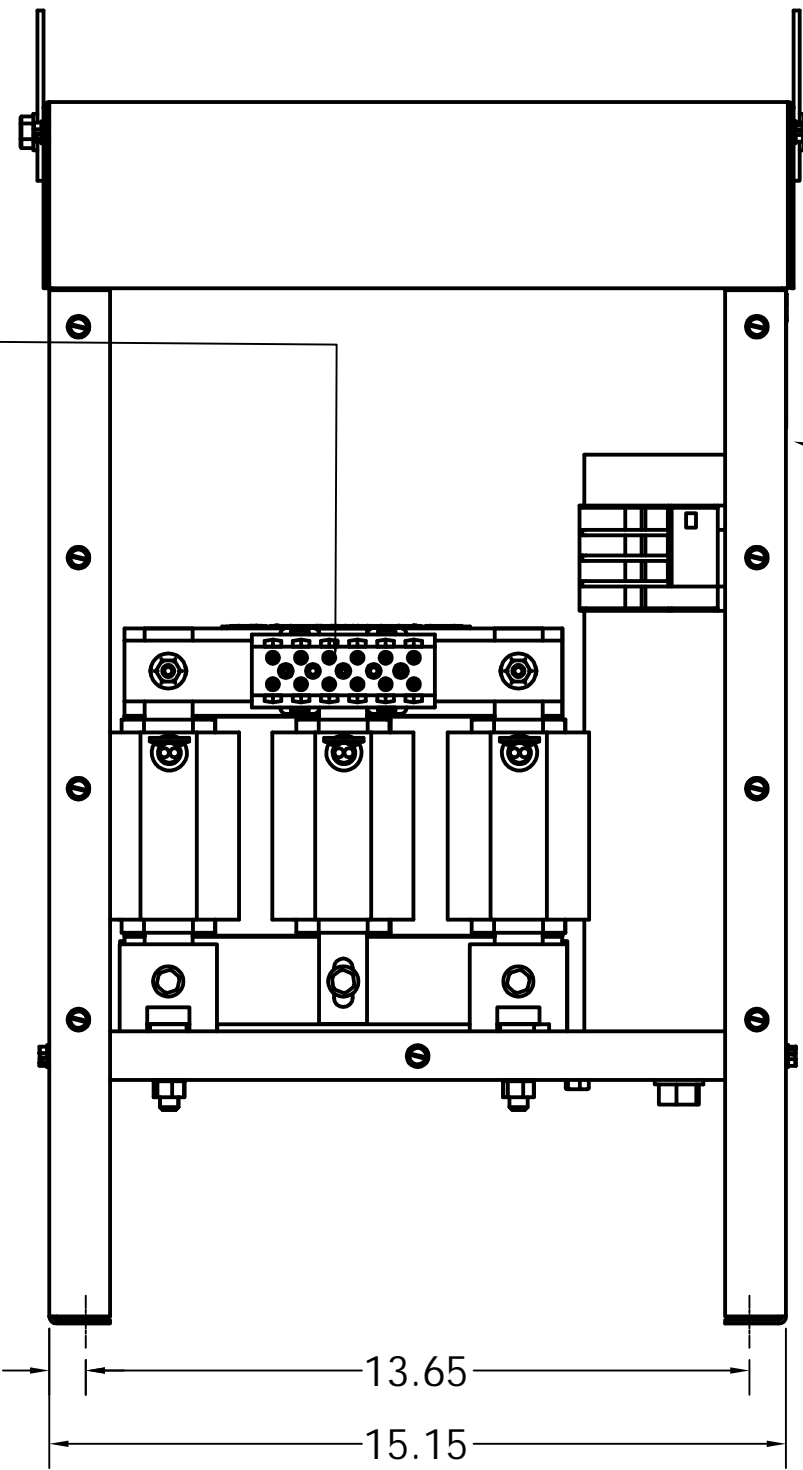

WARNING
WAIT TWO HOURS AFTER
POWER IS TURNED OFF
BEFORE OPENING TO
ALLOW FOR CAPACITOR
DISCHARGE.

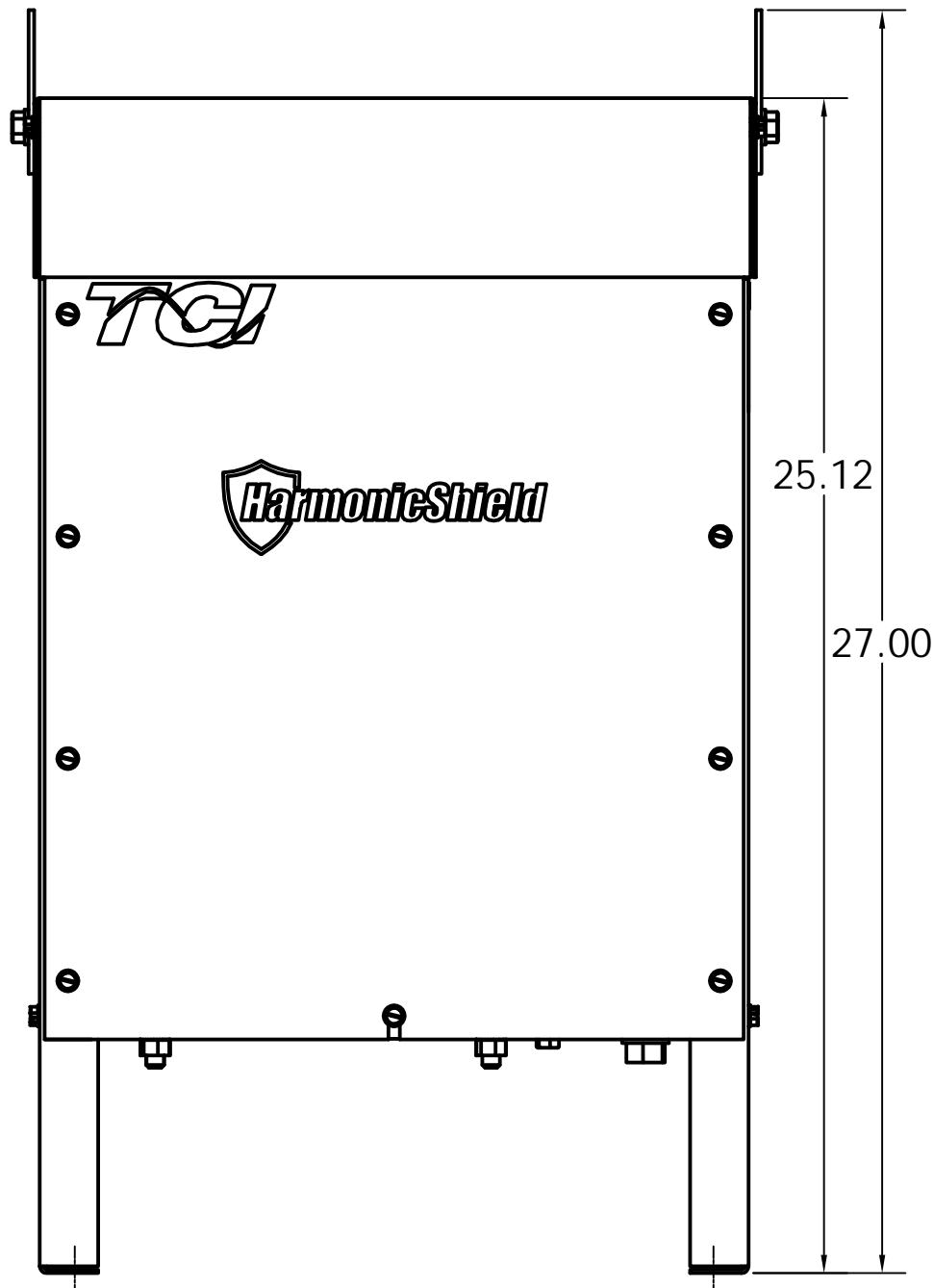

0.50 DIA MOUNTING HOLES
4 PLACES.

CUSTOMER IS RESPONSIBLE FOR INSTALLATION TO MEET
ALL NATIONAL AND LOCAL ELECTRICAL CODES.

NOTE: USE ONLY HUBS OR FITTINGS THAT COMPLY
WITH UL514B FOR TYPE 3R ENCLOSURES.

TOLERANCES (EXCEPT AS NOTED)			
DECIMAL	.XX	+/-	.25
FRACTIONAL	.XXX	+/-	.1
ANGULAR	+/-	1°	

NO	REVISION	DATE	BY
A	AS DESIGNED	7/22/16	DSW

TCI® W132 N10611 Grant Drive
Germantown, WI 53022

HarmonicShield, 600V
25HP, 30HP, 40HP, 50HP

DRN BY: DSW DATE: 7/22/16 DWG. No: 106600DG
SCALE: 1/4"=1'-0" APRVD: SHEET 1 OF 1