

Dimension Table				
Enclosure	"A" Dim	"B" Dim	"C" Dim	"D" Dim
Type 1	16.8	25.6	1.8	0.8
Type 3R	19.5	25.1	3.8	2.1

HP	Volts	Phase	Hz	Harmonic	Kvar	Contactor	PQ Connect	Weight (lbs)
3	480	3	60	5TH	1.2	Without	Without	60
3	480	3	60	5TH	1.2	With	Without	63
3	480	3	60	5TH	1.2	With	With	72
3	600	3	60	5TH	1	Without	Without	60
3	600	3	60	5TH	1	With	Without	63
3	600	3	60	5TH	1	With	With	72
5	480	3	60	5TH	1.2	Without	Without	60
5	480	3	60	5TH	1.2	With	Without	63
5	480	3	60	5TH	1.2	With	With	72
5	600	3	60	5TH	1.6	Without	Without	60
5	600	3	60	5TH	1.6	With	Without	63
5	600	3	60	5TH	1.6	With	With	72
8	480	3	60	5TH	3	Without	Without	77
8	480	3	60	5TH	3	With	Without	80
8	480	3	60	5TH	3	With	With	89
8	600	3	60	5TH	2	Without	Without	77
8	600	3	60	5TH	2	With	Without	80
8	600	3	60	5TH	2	With	With	89
10	480	3	60	5TH	3	Without	Without	77
10	480	3	60	5TH	3	With	Without	80
10	480	3	60	5TH	3	With	With	89
10	600	3	60	5TH	3.1	Without	Without	77
10	600	3	60	5TH	3.1	With	Without	80
10	600	3	60	5TH	3.1	With	With	89

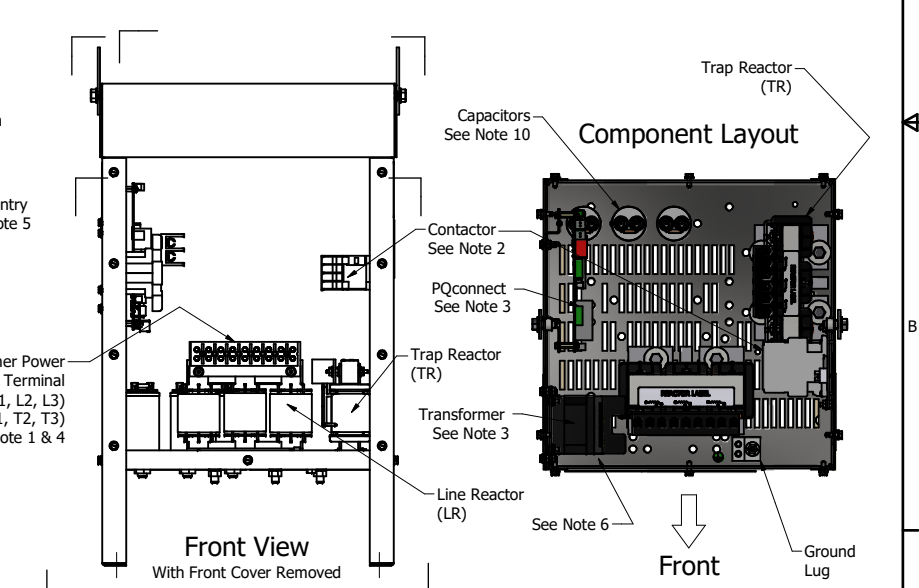
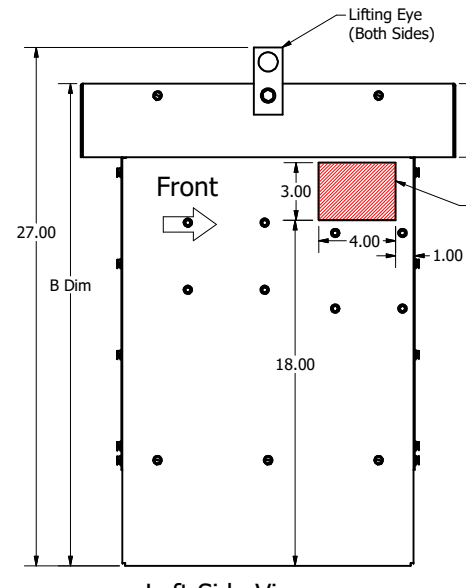
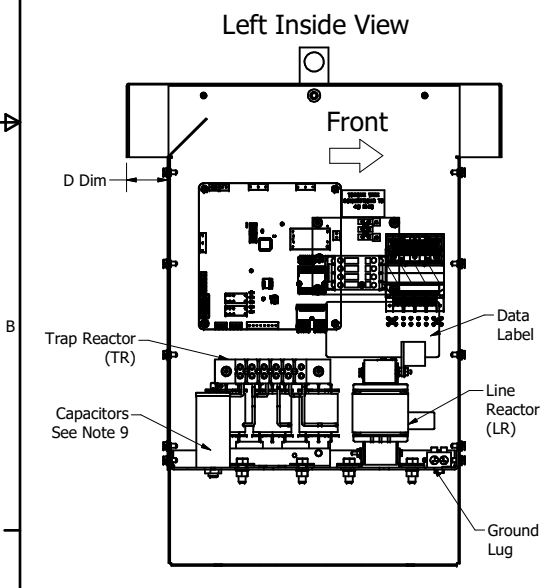

- Notes:
- 1.) Refer to manual for wire size and torque.
 - 2.) Contactor (CNT) and terminal (TB) are optional.
 - 3.) PQconnect with Transformer are optional.
 - 4.) Refer to schematic # 30047-1, PQ Schematic (TBD)
 - 5.) Preferred wire entry area.
 - 6.) Wire entry is allowed through the bottom.
 - 7.) Enclosure is shown with a Type 3R top.
 - 8.) Use only hubs or fittings that comply with UL514B for Type 3R applications
 - 9.) Installation must meet all national and local codes.
 - 10.) Number, size & location can vary per Hp and voltage.

THE INFORMATION AND DESIGNS CONTAINED IN THIS DRAWING ARE CONFIDENTIAL AND THE PROPRIETARY PROPERTY OF ALLIED MOTION TECHNOLOGIES INC. AND ITS SUBSIDIARIES. NEITHER THIS DESIGN NOR ANY INFORMATION CONTAINED IN THIS DRAWING MAY BE REPRODUCED OR DISCLOSED TO OTHERS WITHOUT THE EXPRESS WRITTEN CONSENT OF ALLIED MOTION TECHNOLOGIES INC. AND ITS SUBSIDIARIES.					TOLERANCES (EXCEPT AS NOTED)
					DECIMAL
					.XX ± .25 .XXX ± .10
					FRACTIONAL
	C	Add PQ Connect	7/23/2021	DSW	ANGULAR ± 1/16
	B	Add Type 1 & 600 Volt	4/21/17	RHW	SCALE: 1/5
	A	As Designed	6/16/16	DSW	DATE: 6/6/16
	NO	REVISION	DATE	BY	SCALE: 1/5

Material(s) Shall be RoHS Compliant

W132N10611 Grant Drive
 Germantown, WI 53022
 © 2021 TCL, LLC
 An Official Motion Company
 HarmonicShield, 480 & 600 Volt
 3Hp, 5Hp, 8Hp, 10Hp
 106264DG
 SHEET 1 OF 1